

Data sheet

Thermostatic expansion valves

Type TE 5 – TE 55



The TE 5 - TE 55 series expansion valve regulate the injection of refrigerant into evaporators. It controls the refrigerant flow based on the superheat. The exchangeable power element is produced with the well known Danfoss laser welding technology for extended lifetime capability. The TE 5 - TE 55 series is available with a wide range of orifices which will cover a wide range of applications.

Applications:

- Air conditioning system
- Chiller
- Cold room
- Freezer
- Other refrigeration systems

Features

- Wide operating range:
 - 40 – 10 °C / -40 – 50 °F
 - 60 – -25 °C / -75 – -15 °F
- Refrigerants: R407F, R407A, R448A, R449A, R452A, R404A, R507, R22, R513A, R134a and R407C. *www.MrCool.ir*
- Interchangeable orifice assembly:
 - easy storage
 - easy capacity matching
 - better service
- Laser welded stainless steel power element, capillary tube and bulb.
- Wide capacity range, rated capacity from:
 - R448A/R449A : 9 – 225 kW / 2.5 – 64 TR
 - R407F : 11 – 250 kW / 3 – 71 TR
 - R404A/R507 : 7 – 183 kW / 2 – 52 TR
- MOP function is available.
- Superior charge performance.
- PS / MWP (maximum working pressure): 28 bar / 400 psig.
- Minimized capacity gap and overlap between orifices.
- TE 55 has balanced port design.
- Patented bulb strap design.

Data sheet | Thermostatic expansion valves, type TE 5 – TE 55

Technical data

Max. temperature
 Bulb, when valve is assembled: 100 °C / 210 °F.
 Complete valve when not assembled: 70 °C / 160 °F.
 Min. temperature: -60 °C / -75 °F.

Max. test pressure: 32 bar / 465 psig.
 Maximum working pressure: 28 bar / 400 psig.

MOP-points

SI units

US units

Refrigerant <i>www.MrCool.ir</i>	Range	Range	Range	Range	Range	Range	Range	Range	Range
	-40 – 10 °C	-40 – -5 °C	-40 – -15 °C	-60 – -25 °C	-40 – 50 °F	-40 – 25 °F	-40 – 5 °F	-75 – -15 °F	-75 – -15 °F
	MOP-point in evaporating temperature t_e and evaporating pressure p_e				MOP-point in evaporating temperature t_e and evaporating pressure p_e				
	15 °C	0 °C	-10 °C	-20 °C	60 °F	32 °F	15 °F	-5 °F	
R407F/R407A	7.5 bar	4.2 bar	2.6 bar	1.5 bar	110 psig	60 psig	40 psig	20 psig	
R404A/R507	8.6 bar	5.1 bar	3.4 bar	2.0 bar	120 psig	70 psig	45 psig	30 psig	
R22	6.9 bar	4.0 bar	2.6 bar	1.5 bar	100 psig	60 psig	35 psig	20 psig	
R134a	3.9 bar	2.0 bar	1.0 bar	0.3 bar	55 psig	30 psig	15 psig	5 psig	
R407C	6.6 bar	3.6 bar	2.2 bar	1.1 bar	95 psig	50 psig	30 psig	15 psig	

MOP = Max. Operating Pressure
 For MOP of R448A/R449A, R452A, R513A, please contact Danfoss for more information.

Superheat

SS = static superheat
 OS = opening superheat
 SH = SS + OS = total superheat
 Q_{nom} = rated capacity
 Q_{max} = maximum capacity

Example
 Static superheat SS = 4 K / 7.2 °F
 Opening superheat OS = 4 K / 7.2 °F
 Total superheat SH = 4 + 4 = 8 K
 SH = 7.2 + 7.2 = 14.4 °F

SS can be adjusted with setting spindle.
 The standard factory SS setting is 4 K / 7.2 °F.
 The OS is 4 K / 7.2 °F from when opening begins to where the valve reaches its rated capacity Q_{nom} .
 OS is determined by the design and cannot be changed.

Using orifice with range B element, please check superheat under running conditions and readjust SS setting, if necessary.

Identification

The thermostatic element is fitted with a label (on top of the diaphragm).

The label holds information like valve type, evaporating temperature range, MOP point, refrigerant, max. working pressure PS / MWP and production date.

Production place and date (BE1315B) mean:
 BE = Wuqing, China
 13 = Week
 15 = Year 2015
 B = Tuesday

Orifice assembly for TE 5 – TE 55
 The orifice assembly is marked on top of the spring cup, e.g. as shown in the figure.

TE 12 = For valve type
 06 = Orifice no.
 067B2709 = Orifice code no. for sales order
 1315 = week 13, year 2015

Capillary tube tag for TE 5 – TE 55
 The label gives the orifice size (06). A new label always accompanies a new orifice assembly.



Element label

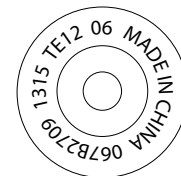

Orifice assembly marking for TE 5 – TE 55



Capillary tube tag TE 5 – TE 55

Design / Function

General

TE 5 – TE 55 valves have an interchangeable orifice assembly.

TE 5 – TE 55 valves are built up of three main components (Parts program):

1. Thermostatic element
2. Orifice assembly
3. Valve body with connections

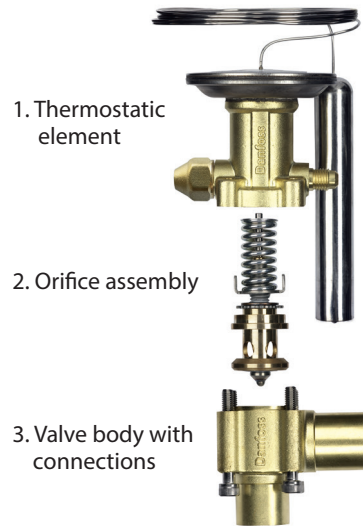

The orifice is refrigerant and range independent.

All valves are equipped with external pressure equalization.

To ensure long operating life, the valve cone and seat are made of a special alloy with particularly good wear properties.

1. Thermostatic element.
2. Interchangeable orifice assembly.
3. Valve body.
4. Superheat setting spindle.
5. External pressure equalizing connection with 1/4 in / 6 mm flare nut (solder is available on TE 5).

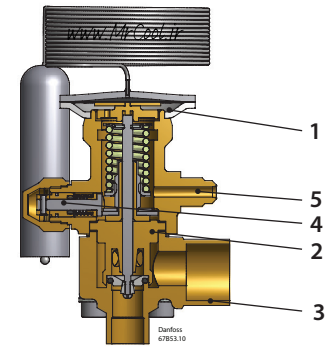

TE 5

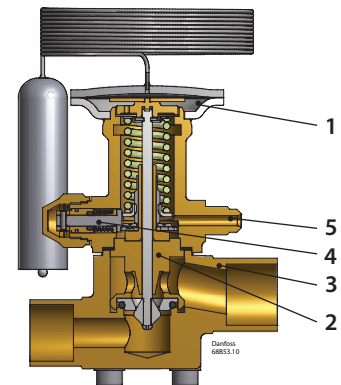

TE 12 / TE 20

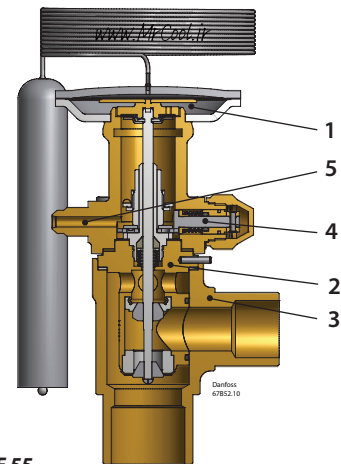

TE 55

Data sheet | Thermostatic expansion valves, type TE 5 – TE 55

Ordering

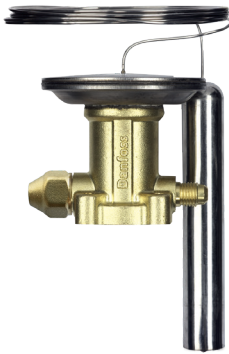

Element for expansion valve - including bulb strap.

R407F/R407A

Valve type	Pressure equalization		MOP		Range		Capillary tube		Code no.
	Size	Type	[°C]	[°F]	[°C]	[°F]	[m]	[in]	
TE 5	1/4 in / 6 mm	Flare	-	-	-40 - 10	-40 - 50	3	118	067B3501
	1/4 in / 6 mm	Flare	0	32	-40 - -5	-40 - 25	3	118	067B3502
	1/4 in / 6 mm	Flare	-10	15	-40 - -15	-40 - 5	3	118	067B3503
	1/4 in	Solder ODF	-	-	-40 - 10	-40 - 50	3	118	067B3504
TE 12	1/4 in / 6 mm	Flare	-	-	-40 - 10	-40 - 50	3	118	067B3532
	1/4 in / 6 mm	Flare	0	32	-40 - -5	-40 - 25	3	118	067B3531
	1/4 in / 6 mm	Flare	-10	15	-40 - -15	-40 - 5	3	118	067B3533
TE 20	1/4 in / 6 mm	Flare	-	-	-40 - 10	-40 - 50	3	118	067B3561
	1/4 in / 6 mm	Flare	0	32	-40 - -5	-40 - 25	3	118	067B3560
	1/4 in / 6 mm	Flare	-10	15	-40 - -15	-40 - 5	3	118	067B3562
TE 55	1/4 in / 6 mm	Flare	-	-	-40 - 10	-40 - 50	3	118	067G3500

Element for expansion valve - including bulb strap.

R448A/R449A

Valve type	Pressure equalization		MOP		Range		Capillary tube		Code no.
	Size	Type	[°C]	[°F]	[°C]	[°F]	[m]	[in]	
TE 5	1/4 in. / 6 mm	Flare	-	-	-40 - 10	-40 - 50	3	118	067B3252
	1/4 in. / 6 mm	Flare	-20	-5	-60 - -25	-75 - -15	3	118	067B3600
TE 12	1/4 in. / 6 mm	Flare	-	-	-40 - 10	-40 - 50	3	118	067B2512
TE 20	1/4 in. / 6 mm	Flare	-	-	-40 - 10	-40 - 50	3	118	067B3294
TE 55	1/4 in. / 6 mm	Flare	-	-	-40 - 10	-40 - 50	3	118	067G3219

Element for expansion valve - including bulb strap.

R452A

Valve type	Pressure equalization		MOP		Range		Capillary tube		Code no.
	Size	Type	[°C]	[°F]	[°C]	[°F]	[m]	[in]	
TE 5	1/4 in. / 6 mm	Flare	-	-	-40 - 10	-40 - 50	3	118	067B3601
	1/4 in. / 6 mm	Flare	-20	-5	-60 - -25	-75 - -15	3	118	067B3602
TE 12	1/4 in. / 6 mm	Flare	-	-	-40 - 10	-40 - 50	3	118	067B3652
TE 20	1/4 in. / 6 mm	Flare	-	-	-40 - 10	-40 - 50	3	118	067B3680
TE 55	1/4 in. / 6 mm	Flare	-	-	-40 - 10	-40 - 50	3	118	067G3600

Data sheet | Thermostatic expansion valves, type TE 5 – TE 55

Ordering

Element for expansion valve - including bulb strap.

R404A/R507

Valve type	Pressure equalization		MOP		Range		Capillary tube		Code no
	Size	Type	[°C]	[°F]	[°C]	[°F]	[m]	[in]	
TE 5	1/4 in / 6 mm	Flare	-	-	-40 - 10	-40 - 50	3	118	067B3342
	1/4 in	Solder ODF	-	-	-40 - 10	-40 - 50	3	118	067B3380
	1/4 in / 6 mm	Flare	15	60	-40 - 10	-40 - 50	3	118	067B3238
	1/4 in / 6 mm	Flare	0	32	-40 - -5	-40 - 25	3	118	067B3357
	1/4 in / 6 mm	Flare	-10	15	-40 - -15	-40 - 5	3	118	067B3358
	1/4 in	Solder ODF	-10	15	-40 - -15	-40 - 5	3	118	067B3384
	1/4 in / 6 mm	Flare	-	-	-60 - -25	-75 - -15	3	118	067B3344
	6 mm	Solder ODF	-	-	-60 - -25	-75 - -15	3	118	067B3392
	1/4 in / 6 mm	Flare	-20	-5	-60 - -25	-75 - -15	3	118	067B3343
1/4 in	Solder ODF	-20	-5	-60 - -25	-75 - -15	3	118	067B3381	
TE 12	1/4 in / 6 mm	Flare	-	-	-40 - 10	-40 - 50	3	118	067B3347
	1/4 in / 6 mm	Flare	0	32	-40 - -5	-40 - 25	3	118	067B3345
	1/4 in / 6 mm	Flare	-10	15	-40 - -15	-40 - 5	3	118	067B3348
	1/4 in / 6 mm	Flare	-20	-5	-60 - -25	-75 - -15	3	118	067B3349
	1/4 in / 6 mm	Flare	-	-	-60 - -25	-75 - -15	3	118	067B3368
	1/4 in / 6 mm	Flare	-	-	-40 - 10	-40 - 50	5	197	067B3346
	1/4 in / 6 mm	Flare	-20	-5	-60 - -25	-75 - -15	5	197	067B3350
TE 20	1/4 in / 6 mm	Flare	-	-	-40 - 10	-40 - 50	3	118	067B3352
	1/4 in / 6 mm	Flare	0	32	-40 - -5	-40 - 25	3	118	067B3351
	1/4 in / 6 mm	Flare	-10	15	-40 - -15	-40 - 5	3	118	067B3353
	1/4 in / 6 mm	Flare	-20	-5	-60 - -25	-75 - -15	3	118	067B3354
	1/4 in / 6 mm	Flare	-	-	-40 - 10	-40 - 50	5	197	067B3356
	1/4 in / 6 mm	Flare	-20	-5	-60 - -25	-75 - -15	5	197	067B3355
TE 55	1/4 in / 6 mm	Flare	-	-	-40 - 10	-40 - 50	3	118	067G3302
	1/4 in / 6 mm	Flare	0	32	-40 - -5	-40 - 25	3	118	067G3303
	1/4 in / 6 mm	Flare	-10	15	-40 - -15	-40 - 5	3	118	067G3304
	1/4 in / 6 mm	Flare	-20	-5	-60 - -25	-75 - -15	3	118	067G3305
	1/4 in / 6 mm	Flare	-	-	-40 - 10	-40 - 50	5	197	067G3301
	1/4 in / 6 mm	Flare	-20	-5	-60 - -25	-75 - -15	5	197	067G3306

Data sheet | Thermostatic expansion valves, type TE 5 – TE 55

Ordering



Element for expansion valve - including bulb strap.

R22/R407C ¹⁾

Valve type	Pressure equalization		MOP		Range		Capillary tube		Code no.
	Size	Type	[°C]	[°F]	[°C]	[°F]	[m]	[in]	
TE 5	1/4 in / 6 mm	Flare	-	-	-40 - 10	-40 - 50	3	118	067B3250
	1/4 in	Solder ODF	-	-	-40 - 10	-40 - 50	3	118	067B3420
	1/4 in / 6 mm	Flare	15	60	-40 - 10	-40 - 50	3	118	067B3267
	1/4 in / 6 mm	Flare	0	32	-40 - 5	-40 - 25	3	118	067B3249
	1/4 in / 6 mm	Flare	-10	15	-40 - -15	-40 - 5	3	118	067B3253
	1/4 in / 6 mm	Flare	-20	-5	-60 - -25	-75 - -15	3	118	067B3263
TE 12	1/4 in / 6 mm	Flare	-	-	-40 - 10	-40 - 50	3	118	067B3210
	1/4 in / 6 mm	Flare	-	-	-40 - 10	-40 - 50	5	197	067B3209
	1/4 in / 6 mm	Flare	15	60	-40 - 10	-40 - 50	3	118	067B3227
	1/4 in / 6 mm	Flare	0	32	-40 - 5	-40 - 25	3	118	067B3207
	1/4 in / 6 mm	Flare	-10	15	-40 - -15	-40 - 5	3	118	067B3213
	1/4 in / 6 mm	Flare	-20	-5	-60 - -25	-75 - -15	3	118	067B3211
	1/4 in / 6 mm	Flare	-	-	-60 - -25	-75 - -15	3	118	067B3225
	1/4 in / 6 mm	Flare	-20	-5	-60 - -25	-75 - -15	5	197	067B3212
TE 20	1/4 in / 6 mm	Flare	-	-	-40 - 10	-40 - 50	3	118	067B3274
	1/4 in / 6 mm	Flare	-	-	-40 - 10	-40 - 50	5	197	067B3290
	1/4 in / 6 mm	Flare	15	60	-40 - 10	-40 - 50	3	118	067B3286
	1/4 in / 6 mm	Flare	0	32	-40 - 5	-40 - 25	3	118	067B3273
	1/4 in / 6 mm	Flare	-10	15	-40 - -15	-40 - 5	3	118	067B3275
	1/4 in / 6 mm	Flare	-20	-5	-60 - -25	-75 - -15	3	118	067B3276
	1/4 in / 6 mm	Flare	-20	-5	-60 - -25	-75 - -15	5	197	067B3287
TE 55	1/4 in / 6 mm	Flare	-	-	-40 - 10	-40 - 50	3	118	067G3205
	1/4 in / 6 mm	Flare	-	-	-40 - 10	-40 - 50	5	197	067G3209
	1/4 in / 6 mm	Flare	15	60	-40 - 10	-40 - 50	3	118	067G3220
	1/4 in / 6 mm	Flare	0	32	-40 - 5	-40 - 25	3	118	067G3206
	1/4 in / 6 mm	Flare	-20	-5	-60 - -25	-75 - -15	3	118	067G3207
	1/4 in / 6 mm	Flare	-20	-5	-60 - -25	-75 - -15	5	197	067G3217

¹⁾ For R407C plants, please select elements from the dedicated R407C program

Element for expansion valve - including bulb strap.

R513A

Valve type	Pressure equalization		MOP		Range		Capillary tube		Code no.
	Size	Type	[°C]	[°F]	[°C]	[°F]	[m]	[in]	
TE 5	1/4 in / 6 mm	Flare	-	-	-40 - 10	-40 - 50	3	118	067B3603
TE 12	1/4 in / 6 mm	Flare	-	-	-40 - 10	-40 - 50	3	118	067B3651
TE 20	1/4 in / 6 mm	Flare	-	-	-40 - 10	-40 - 50	3	118	067B3681
TE 55	1/4 in / 6 mm	Flare	-	-	-40 - 10	-40 - 50	3	118	067G3601

Element for expansion valve - including bulb strap.

R134a

Valve type	Pressure equalization		MOP		Range		Capillary tube		Code no.
	Size	Type	[°C]	[°F]	[°C]	[°F]	[m]	[in]	
TE 5	1/4 in / 6 mm	Flare	-	-	-40 - 10	-40 - 50	3	118	067B3297
	1/4 in	Solder ODF	-	-	-40 - 10	-40 - 50	3	118	067B3430
	1/4 in / 6 mm	Flare	15	60	-40 - 10	-40 - 50	3	118	067B3298
TE 12	1/4 in / 6 mm	Flare	-	-	-40 - 10	-40 - 50	3	118	067B3232
	1/4 in / 6 mm	Flare	15	60	-40 - 10	-40 - 50	3	118	067B3233
	1/4 in / 6 mm	Flare	-	-	-40 - 10	-40 - 50	5	197	067B3363
TE 20	1/4 in / 6 mm	Flare	-	-	-40 - 10	-40 - 50	3	118	067B3292
	1/4 in / 6 mm	Flare	15	60	-40 - 10	-40 - 50	3	118	067B3293
	1/4 in / 6 mm	Flare	-	-	-40 - 10	-40 - 50	5	197	067B3370
TE 55	1/4 in / 6 mm	Flare	-	-	-40 - 10	-40 - 50	3	118	067G3222
	1/4 in / 6 mm	Flare	15	60	-40 - 10	-40 - 50	3	118	067G3223
	1/4 in / 6 mm	Flare	-	-	-40 - 10	-40 - 50	5	197	067G3230

Data sheet | Thermostatic expansion valves, type TE 5 – TE 55

Ordering

Element for expansion valve - including bulb strap.

R407C

Valve type	Pressure equalization		MOP		Range		Capillary tube		Code no.
	Size	Type	[°C]	[°F]	[°C]	[°F]	[m]	[in]	
TE 5	1/4 in / 6 mm	Flare	–	–	-40 – 10	-40 – 50	3	118	067B3278
	1/4 in / 6 mm	Flare	15	60	-40 – 10	-40 – 50	3	118	067B3277
TE 12	1/4 in / 6 mm	Flare	–	–	-40 – 10	-40 – 50	3	118	067B3366
	1/4 in / 6 mm	Flare	15	60	-40 – 10	-40 – 50	3	118	067B3367
TE 20	1/4 in / 6 mm	Flare	–	–	-40 – 10	-40 – 50	5	197	067B3371
	1/4 in / 6 mm	Flare	15	60	-40 – 10	-40 – 50	5	197	067B3372
TE 55	1/4 in / 6 mm	Flare	–	–	-40 – 10	-40 – 50	5	197	067G3240
	1/4 in / 6 mm	Flare	15	60	-40 – 10	-40 – 50	5	197	067G3241

Orifice for expansion valves. Rated capacity.



Valve type	Orifice no.	R407F	R407A	R448A/R449A	R452A	R404A/R507	R22	R513A	R134a	R407C	R407F	R407A	R448A/R449A	R452A	R404A/R507	R22	R513A	R134a	R407C	Code no.
		[kW]										www.MrCool.ir [TR]								
TE 5	0.5	11	9	9	7	7	9	5	5	11	3	2.5	2.5	2	2	2.5	1.5	1.5	3	067B2788
	01	18	18	18	14	14	16	11	11	18	5	5	5	4	4	4.5	3	3	5	067B2789
	02	28	25	25	21	19	25	14	16	25	8	7	7	6	5.5	7	4	4.5	7	067B2790
	03	35	32	32	28	25	32	18	21	32	10	9	9	8	7	9	5	6	9	067B2791
	04	46	42	46	39	35	42	25	28	46	13	12	13	11	10	12	7	8	13	067B2792
TE 12	05	70	56	53	46	49	56	30	35	53	20	16	15	13	14	16	8.5	10	15	067B2708
	06	95	74	70	63	63	74	39	49	74	27	21	20	18	18	21	11	14	21	067B2709
	07	113	95	91	81	81	95	49	63	91	32	27	26	23	23	27	14	18	26	067B2710
TE 20	08	141	127	123	84	84	127	74	77	116	40	36	35	24	24	36	21	22	33	067B2771¹⁾
	09	158	148	141	98	102	148	81	91	134	45	42	40	28	29	42	23	26	38	067B2773¹⁾
TE 55	9B	123	109	113	84	84	113	70	74	109	35	31	32	24	24	32	20	21	31	067G2705²⁾
	10	172	165	155	116	127	169	98	109	162	49	47	44	33	36	48	28	31	46	067G2701
	11	186	183	169	127	137	183	106	120	176	53	52	48	36	39	52	30	34	50	067G2704
	12	208	200	186	141	151	200	116	134	190	59	57	53	40	43	57	33	38	54	067G2707
	13	250	243	225	172	183	246	144	165	232	71	69	64	49	52	70	41	47	66	067G2710

The rated capacity is based on:

Evaporating temperature $t_e = 4.4\text{ °C} / 40\text{ °F}$
 Condensing temperature $t_c = 38\text{ °C} / 100\text{ °F}$
 Refrigerant temperature ahead of valve $t_r = 37\text{ °C} / 98\text{ °F}$

- ¹⁾ Recommend to use orifice no. 9B as alternative for orifice no. 08 and 09 on TE 55 when selecting the valve to work in range -60 – -25 °C / -75 – -15 °F. Extend capacity tables for range -60 – -25 °C / -75 – -15 °F are not provided.
- ²⁾ Alternative for orifice no. 08 and 09 in range -60 – -25 °C / -75 – -15 °F. Extend capacity tables for range -40 – 10 °C / -40 – 50 °F are not provided.

Data sheet | Thermostatic expansion valves, type TE 5 – TE 55

Ordering

Valve body for expansion valves



Flare angleway



Solder straightway



Solder straightway



Flanges



Solder angleway

www.MrCool.ir

Type	Connection Inlet × Outlet		Connections / Flow direction <i>www.MrCool.ir</i>	Connection type ¹⁾	Code no.
	[in]	[mm]			
TE 5	$1/2 \times 5/8$	12 × 16	Flare angleway	–	067B4013
	$1/2 \times 5/8$	–	Solder angleway	ODF × ODF	067B4009
	$1/2 \times 7/8$	–	Solder angleway	ODF × ODF	067B4010
	$5/8 \times 7/8$	–	Solder angleway	ODF × ODF	067B4011
	$7/8 \times 1 1/8$	–	Solder angleway	ODF × ODM	067B4034
	$1/2 \times 5/8$	–	Solder straightway	ODF × ODF	067B4007
	$1/2 \times 7/8$	–	Solder straightway	ODF × ODF	067B4008
	$5/8 \times 7/8$	–	Solder straightway	ODF × ODF	067B4032
	$7/8 \times 1 1/8$	–	Solder straightway	ODF × ODM	067B4033
	–	12 × 16	Solder angleway	ODF × ODF	067B4004
	–	12 × 22	Solder angleway	ODF × ODF	067B4005
	–	16 × 22	Solder angleway	ODF × ODF	067B4012
	–	22 × 28	Solder angleway	ODF × ODM	067B4037
	–	12 × 16	Solder straightway	ODF × ODF	067B4002
	–	12 × 22	Solder straightway	ODF × ODF	067B4003
–	16 × 22	Solder straightway	ODF × ODF	067B4035	
–	22 × 28	Solder straightway	ODF × ODM	067B4036	

TE 12	$5/8 \times 7/8$	–	Solder angleway	ODF × ODF	067B4022
	$7/8 \times 1 1/8$	–	Solder angleway	ODF × ODM	067B4023
	$5/8 \times 7/8$	–	Solder straightway	ODF × ODF	067B4020
	$7/8 \times 1 1/8$	–	Solder straightway	ODF × ODM	067B4021
	–	22 × 28	Solder angleway	ODF × ODM	067B4017
	–	16 × 22	Solder straightway	ODF × ODF	067B4018
–	22 × 28	Solder straightway	ODF × ODM	067B4016	

TE 12	$5/8 \times 7/8$	–	Solder flanges	ODF × ODF	067B4025
	$7/8 \times 1$	–	Solder flanges	ODF × ODF	067B4026
	–	16 × 22	Solder flanges	ODF × ODF	067B4027
	–	22 × 25	Solder flanges	ODF × ODF	067B4015

TE 20	$7/8 \times 1 1/8$	–	Solder angleway	ODF × ODM	067B4023
	–	22 × 28	Solder angleway	ODF × ODM	067B4017
	$7/8 \times 1 1/8$	–	Solder straightway	ODF × ODM	067B4021
	–	22 × 28	Solder straightway	ODF × ODM	067B4016

TE 55	$1 1/8 \times 1 3/8$	–	Solder angleway	ODM × ODM	067G4004
	–	28 × 35	Solder angleway	ODM × ODM	067G4002
	$1 1/8 \times 1 3/8$	–	Solder straightway	ODM × ODM	067G4003
	–	28 × 35	Solder straightway	ODM × ODM	067G4001

¹⁾ ODF = Internal diameter
ODM = External diameter

Spareparts

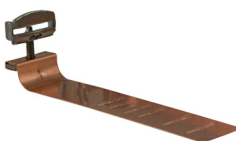

Bulb straps (delivered separately) in Industrial pack

Type	Max. tube diameter	Code no.
TE 5 / TE 12	2 1/8 in / 53 mm	067N0557
TE 20 / TE 55	3 1/8 in / 78 mm	067N0559

Data sheet | Thermostatic expansion valves, type TE 5 – TE 55

How to select a valve

Example:

Q (capacity) = 45 kW
 T_{con} (condensing temperature) = 25 °C
 T_{evap} (evaporator temperature) = -30 °C
 T_{sub} (subcooling temperature) = 10 K
 D_{pd} (distributer pressure drop) = 2 bar

Q (capacity) = 45 kW
 f_{sub} (subcooling correction factor) = 1.09
 f_p (distributer correction factor) = 0.92

SI units

$$\frac{Q}{f_{sub} \times f_p} = \text{Selected capacity}$$

$$\frac{50}{1.09 \times 0.92} = 44.9 \text{ kW}$$

The selection will be:
 TE 20 orifice 9 (54.2 kW > 44.9 kW)

US units

Q (capacity) = 14 TR
 T_{con} (condensing temperature) = 75 °F
 T_{evap} (evaporator temperature) = -20 °F
 T_{sub} (subcooling temperature) = 10 °F
 D_{pd} (distributer pressure drop) = 30 psi

Q (capacity) = 14 TR
 f_{sub} (subcooling correction factor) = 1.03
 f_p (distributer correction factor) = 0.92

$$\frac{Q}{f_{sub} \times f_p} = \text{Selected capacity}$$

$$\frac{14}{1.03 \times 0.92} = 14.8 \text{ TR}$$

The selection will be:
 TE 20 orifice 9 (16.1 TR > 14.8 TR)

Capacity in kW. Range: -40 – 10 °C.
 Opening superheat sh = 4 K

**SI units
R404A/R507**

Valve type	Orifice no.	Cond. temp. [°C]	Evap. temp. [°C]		
			-40	-30	-20
TE 20	8	25	35.7	48.4	62.2
	9	25	39.5	54.2	71.3
	10	25	46.5	64.9	86.1
TE 55	11	25	51.1	71.2	94.4
	12	25	54.8	76.8	103
	13	25	66.5	93.7	126

Subcooling correction factor, f_{sub}

Subcooling [K]	2	4	10	15
Correction factor	0,97	1,00	1,09	1,16

**SI units
R404A/R507**

Distributer correction factor, f_p

Pressure drop [bar] Δp	Evap. temp. [°C]			
	-40	-30	-20	-10
	Correction factor			
0	1	1	1	1
1	0.96	0.96	0.96	0.95
1.5	0.94	0.94	0.94	0.93
2	0.92	0.92	0.91	0.90

Calculated at 32 °C condensing temperature.

Capacity in kW. Range: -40 – 50 °F.
 Opening superheat sh = 7.2 °F.

**US units
R404A/R507**

Valve type	Orifice no.	Cond. temp. [°F]	Evap. temp. [°F]		
			-40	-20	0
TE 20	08	75	10.2	14.2	18.6
	09	75	11.3	16.1	21.5
	10	75	13.4	19.2	26.0
TE 55	11	75	14.7	21.1	28.5
	12	75	15.8	22.8	31.1
	13	75	19.2	27.9	38.2

Subcooling correction factor, f_{sub}

Subcooling [°F]	2	7	10	20
Correction factor	0.96	1.00	1.03	1.11

**US units
R404A/R507**

Distributer correction factor, f_p

Pressure drop [psi] Δp	Evap. temp. [°F]			
	-40	-20	0	20
	Correction factor			
0	1	1	1	1
15	0.96	0.96	0.96	0.95
25	0.94	0.93	0.92	0.91
30	0.92	0.92	0.91	0.89

Calculated at 90 °F condensing temperature.

Data sheet | Thermostatic expansion valves, type TE 5 – TE 55

Capacity in kW. Range: -40 – 10 °C.
Opening superheat sh = 4 K

SI units R407F

Valve type	Orifice no.	Cond. temp. [°C]	Evap. temp. [°C]					
			-40	-30	-20	-10	0	10
TE 5	0.5	25	4.70	5.94	7.36	8.83	10.06	10.5
	01	25	8.60	10.9	13.5	16.2	18.4	19.1
	02	25	12.0	15.3	19.0	22.7	25.5	26.1
	03	25	15.3	19.4	24.1	28.8	32.8	34.1
	04	25	20.3	26.0	32.6	39.4	44.7	46.1
TE 12	05	25	26.1	34.7	45.0	56.7	67.3	70.9
	06	25	32.8	44.3	58.4	74.6	89.4	94.4
	07	25	42.6	59.2	77.5	96.2	113	124
TE 20	08	25	52.3	69.5	90.2	113	131	134
	09	25	56.6	76.3	101	130	155	162
TE 55	10	25	65.7	86.2	111	139	164	177
	11	25	72.3	94.9	123	153	180	193
	12	25	77.7	103	133	167	200	216
	13	25	94.7	126	163	206	245	262

Capacity in TR. Range: -40 – 50 °F.
Opening superheat sh = 7.2 °F.

US units R407F

Valve type	Orifice no.	Cond. temp. [°F]	Evap. temp. [°F]					
			-40	-20	0	20	40	50
TE 5	0.5	75	1.33	1.72	2.17	2.62	2.91	2.92
	01	75	2.44	3.17	4.00	4.81	5.32	5.32
	02	75	3.41	4.44	5.60	6.70	7.32	7.26
	03	75	4.34	5.64	7.11	8.55	9.48	9.49
	04	75	5.76	7.58	9.66	11.7	12.9	12.8
TE 12	05	75	7.42	10.2	13.5	17.2	19.7	19.7
	06	75	9.32	13.0	17.6	22.7	26.2	26.2
	07	75	12.0	17.4	23.2	29.0	33.6	34.7
TE 20	08	75	14.9	20.4	27.0	33.8	37.8	37.3
	09	75	16.1	22.5	30.6	39.5	45.4	45.1
TE 55	10	75	18.8	25.3	33.4	42.0	48.4	49.4
	11	75	20.7	27.9	36.8	46.1	52.9	53.9
	12	75	22.3	30.3	40.1	50.8	59.1	60.3
	13	75	27.2	37.1	49.3	62.6	72.3	73.2

Capacity in kW. Range: -40 – 10 °C.
Opening superheat sh = 4 K

SI units R407F

Valve type	Orifice no.	Cond. temp. [°C]	Evap. temp. [°C]					
			-40	-30	-20	-10	0	10
TE 5	0.5	35	4.70	5.98	7.49	9.14	10.7	11.9
	01	35	8.60	11.0	13.8	16.8	19.7	21.7
	02	35	12.0	15.4	19.4	23.6	27.4	29.9
	03	35	15.2	19.4	24.4	29.7	34.8	38.5
	04	35	20.0	26.0	33.0	40.6	47.7	52.0
TE 12	05	35	25.8	33.8	43.6	55.6	68.8	79.0
	06	35	31.9	42.6	56.1	72.8	91.3	106
	07	35	43.6	58.0	75.1	93.7	112	129
TE 20	08	35	51.2	67.4	87.6	112	136	153
	09	35	54.3	71.9	94.9	123	156	181
TE 55	10	35	61.4	81.6	107	137	167	191
	11	35	67.2	89.3	117	150	182	208
	12	35	70.7	94.5	124	160	200	233
	13	35	84.6	113	150.1	195	243	282

Capacity in TR. Range: -40 – 50 °F.
Opening superheat sh = 7.2 °F.

US units R407F

Valve type	Orifice no.	Cond. temp. [°F]	Evap. temp. [°F]					
			-40	-20	0	20	40	50
TE 5	0.5	95	1.33	1.74	2.23	2.75	3.21	3.37
	01	95	2.44	3.20	4.11	5.06	5.89	6.16
	02	95	3.41	4.49	5.77	7.09	8.17	8.48
	03	95	4.32	5.67	7.26	8.95	10.4	10.9
	04	95	5.69	7.57	9.83	12.2	14.3	14.9
TE 12	05	95	7.33	9.87	13.1	17.0	21.1	22.6
	06	95	9.07	12.5	16.9	22.4	28.1	30.2
	07	95	12.4	17.0	22.5	28.4	34.2	36.6
TE 20	08	95	14.6	19.7	26.3	34.1	41.3	43.5
	09	95	15.4	21.1	28.6	38.1	47.9	51.3
TE 55	10	95	17.4	23.9	32.2	41.8	50.9	54.3
	11	95	19.1	26.2	35.3	45.7	55.4	58.9
	12	95	20.1	27.7	37.4	49.3	61.4	66.2
	13	95	24.0	33.3	45.3	59.8	74.5	80.1

Subcooling correction factor, f_{sub}

Subcooling [K]	2	4	10	15	20	25	30
Correction factor	0.98	1.00	1.07	1.12	1.17	1.23	1.28

Subcooling correction factor, f_{sub}

Subcooling [°F]	2	7	10	20	30	40	50
Correction factor	0.97	1.00	1.02	1.08	1.15	1.21	1.27

Distributer correction factor, f_p

SI units R407F

Pressure drop [bar] Δp	Evap. temp. [°C]					
	-40	-30	-20	-10	0	10
0	1	1	1	1	1	1
1	0.97	0.96	0.96	0.96	0.95	0.94
1.5	0.95	0.95	0.94	0.94	0.93	0.91
2	0.93	0.93	0.92	0.91	0.90	0.87

Calculated at 32 °C condensing temperature.

Distributer correction factor, f_p

US units R407F

Pressure drop [psi] Δp	Evap. temp. [°C]					
	-40	-20	0	20	40	50
0	1	1	1	1	1	1
15	0.96	0.96	0.96	0.95	0.95	0.94
25	0.94	0.94	0.93	0.92	0.91	0.89
30	0.93	0.92	0.92	0.91	0.89	0.87

Calculated at 90 °F condensing temperature.

Data sheet | Thermostatic expansion valves, type TE 5 – TE 55

Capacity in kW. Range: -40 – 10 °C.
Opening superheat sh = 4 K

SI units R407F

Valve type	Orifice no.	Cond. temp. [°C]	Evap. temp. [°C]					
			-40	-30	-20	-10	0	10
TE 5	0.5	45	4.58	5.86	7.39	9.11	10.9	12.4
	01	45	8.36	10.7	13.6	16.8	20.0	22.7
	02	45	11.7	15.1	19.1	23.6	28.0	31.5
	03	45	14.7	18.9	23.9	29.5	35.2	40.0
	04	45	19.2	25.0	32.2	40.2	48.3	54.8
TE 12	05	45	25.2	32.3	41.2	52.3	65.6	79.5
	06	45	30.7	40.2	52.5	68.0	87.0	107
	07	45	41.9	54.0	69.3	87.0	106	125
TE 20	08	45	49.5	64.2	82.8	106	132	157
	09	45	51.5	66.8	86.9	113	145	179
TE 55	10	45	55.2	74.2	98.8	129	162	192
	11	45	60.0	80.8	108	140	175	207
	12	45	62.3	83.9	112	146	187	229
	13	45	73.1	99.0	132	175	224	274

Capacity in TR. Range: -40 – 50 °F.
Opening superheat sh = 7.2 °F.

US units R407F

Valve type	Orifice no.	Cond. temp. [°F]	Evap. temp. [°F]					
			-40	-20	0	20	40	50
TE 5	0.5	115	1.29	1.70	2.19	2.75	3.29	3.52
	01	115	2.36	3.12	4.04	5.07	6.05	6.47
	02	115	3.29	4.38	5.69	7.13	8.45	8.97
	03	115	4.14	5.48	7.10	8.90	10.6	11.4
	04	115	5.40	7.27	9.58	12.2	14.6	15.6
TE 12	05	115	7.12	9.37	12.3	15.9	20.3	22.4
	06	115	8.66	11.7	15.6	20.8	27.1	30.2
	07	115	11.8	15.6	20.5	26.2	32.3	35.2
TE 20	08	115	14.0	18.6	24.6	32.2	40.6	44.4
	09	115	14.5	19.4	25.9	34.6	45.1	50.4
TE 55	10	115	15.5	21.5	29.5	39.3	49.6	54.2
	11	115	16.8	23.4	32.1	42.7	53.7	58.6
	12	115	17.4	24.2	33.2	44.7	57.9	64.5
	13	115	20.4	28.6	39.4	53.3	69.5	77.3

Capacity in kW. Range: -40 – 10 °C.
Opening superheat sh = 4 K

SI units R407F

Valve type	Orifice no.	Cond. temp. [°C]	Evap. temp. [°C]					
			-40	-30	-20	-10	0	10
TE 5	0.5	55	4.33	5.56	7.06	8.77	10.6	12.3
	01	55	7.89	10.2	13.0	16.2	19.5	22.6
	02	55	11.0	14.3	18.3	22.9	27.5	31.6
	03	55	13.7	17.8	22.7	28.2	34.1	39.5
	04	55	17.7	23.4	30.3	38.4	46.8	54.3
TE 12	05	55	24.3	30.6	38.3	48.0	59.8	73.6
	06	55	29.1	37.5	48.1	61.8	79.0	99.2
	07	55	37.6	47.1	60.4	76.7	95.2	115
TE 20	08	55	47.3	60.3	76.8	97.4	122	149
	09	55	48.6	61.6	78.6	101	130	163
TE 55	10	55	47.2	64.2	86.7	115	148	180
	11	55	51.0	69.3	93.7	124	159	194
	12	55	53.0	71.9	96.3	127	166	208
	13	55	61.0	83.3	112	150	196	247

Capacity in TR. Range: -40 – 50 °F.
Opening superheat sh = 7.2 °F.

US units R407F

Valve type	Orifice no.	Cond. temp. [°F]	Evap. temp. [°F]					
			-40	-20	0	20	40	50
TE 5	0.5	135	1.21	1.60	2.08	2.63	3.19	3.45
	01	135	2.20	2.93	3.83	4.85	5.89	6.37
	02	135	3.06	4.10	5.40	6.86	8.29	8.91
	03	135	3.82	5.10	6.66	8.44	10.3	11.1
	04	135	4.91	6.69	8.92	11.5	14.1	15.3
TE 12	05	135	6.84	8.78	11.2	14.3	18.2	20.4
	06	135	8.16	10.8	14.1	18.6	24.3	27.5
	07	135	10.3	13.2	17.4	22.7	28.6	31.8
TE 20	08	135	13.3	17.3	22.6	29.2	37.3	41.5
	09	135	13.6	17.6	23.0	30.3	39.7	45.1
TE 55	10	135	12.8	18.1	25.3	34.5	44.9	50.0
	11	135	13.8	19.5	27.3	37.2	48.3	53.7
	12	135	14.5	20.3	28.1	38.2	50.6	57.3
	13	135	16.5	23.4	32.6	44.7	59.8	67.9

Subcooling correction factor, f_{sub}

Subcooling [K]	2	4	10	15	20	25	30
Correction factor	0.98	1.00	1.07	1.12	1.17	1.23	1.28

Subcooling correction factor, f_{sub}

Subcooling [°F]	2	7	10	20	30	40	50
Correction factor	0.97	1.00	1.02	1.08	1.15	1.21	1.27

Distributer correction factor, f_p

SI units R407F

Pressure drop [bar] Δp	Evap. temp. [°C]					
	-40	-30	-20	-10	0	10
	Correction factor					
0	1	1	1	1	1	1
1	0.97	0.96	0.96	0.96	0.95	0.94
1.5	0.95	0.95	0.94	0.94	0.93	0.91
2	0.93	0.93	0.92	0.91	0.90	0.87

Calculated at 32 °C condensing temperature.

Distributer correction factor, f_p

US units R407F

Pressure drop [psi] Δp	Evap. temp. [°F]					
	-40	-20	0	20	40	50
	Correction factor					
0	1	1	1	1	1	1
15	0.96	0.96	0.96	0.95	0.95	0.94
25	0.94	0.94	0.93	0.92	0.91	0.89
30	0.93	0.92	0.92	0.91	0.89	0.87

Calculated at 90 °F condensing temperature.

Data sheet | Thermostatic expansion valves, type TE 5 – TE 55

Capacity in kW. Range: -40 – 10 °C.
Opening superheat sh = 4 K

SI units R407A

Valve type	Orifice no.	Cond. temp. [°C]	Evap. temp. [°C]					
			-40	-30	-20	-10	0	10
TE 5	0.5	25	4.36	5.50	6.80	8.10	9.14	9.44
	01	25	8.00	10.1	12.5	14.9	16.7	17.2
	02	25	11.2	14.2	17.5	20.7	23.1	23.5
	03	25	14.2	18.0	22.3	26.6	29.9	30.5
	04	25	19.0	24.2	30.2	36.2	40.6	41.2
TE 12	05	25	19.7	26.4	34.3	42.7	49.9	52.8
	06	25	25.1	33.8	44.4	56.0	66.1	70.3
	07	25	32.6	43.9	58.1	74.1	88.2	94.2
TE 20	08	25	46.6	59.8	75.2	91.3	104	107
	09	25	51.3	66.8	85.6	106	124	130
TE 55	10	25	60.0	77.7	99.1	123	145	156
	11	25	66.1	85.6	109	135	159	171
	12	25	71.2	92.4	118	148	176	191
	13	25	86.9	113	146	182	216	232

Capacity in TR. Range: -40 – 50 °F.
Opening superheat sh = 7.2 °F.

US units R407A

Valve type	Orifice no.	Cond. temp. [°F]	Evap. temp. [°F]					
			-40	-20	0	20	40	50
TE 5	0.5	75	1.24	1.60	2.01	2.40	2.63	2.63
	01	75	2.27	2.94	3.69	4.39	4.79	4.77
	02	75	3.19	4.13	5.15	6.09	6.59	6.52
	03	75	4.03	5.24	6.60	7.86	8.56	8.49
	04	75	5.40	7.07	8.95	10.7	11.6	11.5
TE 12	05	75	5.62	7.75	10.3	12.9	14.6	14.7
	06	75	7.16	9.96	13.4	16.9	19.4	19.6
	07	75	9.32	13.0	17.6	22.5	26.0	26.3
TE 20	08	75	13.3	18.0	22.4	27.2	30.0	29.8
	09	75	14.7	20.0	25.7	32.1	36.2	36.2
TE 55	10	75	17.2	22.8	29.7	37.1	42.8	43.6
	11	75	19.0	25.2	32.7	40.8	46.9	47.8
	12	75	20.0	27.2	35.6	44.8	52.1	53.4
	13	75	25.0	33.4	43.9	55.3	63.9	64.9

Capacity in kW. Range: -40 – 10 °C.
Opening superheat sh = 4 K

SI units R407A

Valve type	Orifice no.	Cond. temp. [°C]	Evap. temp. [°C]					
			-40	-30	-20	-10	0	10
TE 5	0.5	35	4.25	5.41	6.78	8.30	9.75	10.8
	01	35	7.79	9.93	12.5	15.2	17.9	20.0
	02	35	10.9	14.0	17.5	21.3	24.8	27.0
	03	35	13.7	17.5	22.1	27.1	31.8	34.8
	04	35	18.2	23.5	29.8	36.8	43.3	47.2
TE 12	05	35	18.9	25.0	32.6	41.6	50.8	57.9
	06	35	23.7	31.7	41.9	54.2	67.1	77.2
	07	35	30.1	39.9	52.9	68.9	86.3	100
TE 20	08	35	43.9	56.5	72.0	89.9	107	120
	09	35	47.2	61.3	79.3	101	124	142
TE 55	10	35	54.5	71.5	92.8	118	146	169
	11	35	59.7	78.2	101	129	159	184
	12	35	63.7	83.7	109	139	173	203
	13	35	76.4	100	132	169	211	246

Capacity in TR. Range: -40 – 50 °F.
Opening superheat sh = 7.2 °F.

US units R407A

Valve type	Orifice no.	Cond. temp. [°F]	Evap. temp. [°F]					
			-40	-20	0	20	40	50
TE 5	0.5	95	1.21	1.58	2.02	2.50	2.92	3.06
	01	95	2.21	2.89	3.71	4.59	5.34	5.58
	02	95	3.10	4.07	5.20	6.40	7.38	7.66
	03	95	3.89	5.11	6.57	8.15	9.49	9.88
	04	95	5.15	6.84	8.89	11.1	12.9	13.4
TE 12	05	95	5.36	7.31	9.80	12.7	15.5	16.4
	06	95	6.73	9.30	12.6	16.6	20.5	21.9
	07	95	8.55	11.7	15.9	21.2	26.5	28.5
TE 20	08	95	12.5	16.5	21.5	27.3	32.4	34.0
	09	95	13.4	17.9	23.8	31.0	37.9	40.2
TE 55	10	95	15.5	20.9	27.9	36.2	44.7	48.1
	11	95	16.9	22.9	30.5	39.6	48.7	52.3
	12	95	18.1	24.5	32.8	42.9	53.4	57.7
	13	95	21.7	29.5	39.7	52.2	64.9	69.9

Subcooling correction factor, f_{sub}

Subcooling [K]	2	4	10	15	20	25	30
Correction factor	0.98	1.00	1.07	1.13	1.19	1.24	1.30

Subcooling correction factor, f_{sub}

Subcooling [°F]	2	7	10	20	30	40	50
Correction factor	0.97	1.00	1.02	1.09	1.16	1.23	1.29

Distributer correction factor, f_p

SI units R407A

Pressure drop [bar] Δp	Evap. temp. [°C]					
	-40	-30	-20	-10	0	10
0	1	1	1	1	1	1
1	0.96	0.96	0.96	0.96	0.95	0.94
1.5	0.95	0.94	0.94	0.93	0.92	0.90
2	0.93	0.92	0.92	0.91	0.89	0.87

Calculated at 32 °C condensing temperature.

Distributer correction factor, f_p

US units R407A

Pressure drop [psi] Δp	Evap. temp. [°F]					
	-40	-20	0	20	40	50
0	1	1	1	1	1	1
15	0.96	0.96	0.96	0.95	0.94	0.93
25	0.94	0.93	0.93	0.92	0.90	0.89
30	0.92	0.92	0.91	0.90	0.88	0.86

Calculated at 90 °F condensing temperature.

Data sheet | Thermostatic expansion valves, type TE 5 – TE 55

Capacity in kW. Range: -40 – 10 °C.
Opening superheat sh = 4 K

SI units R407A

Valve type	Orifice no.	Cond. temp. [°C]	Evap. temp. [°C]					
			-40	-30	-20	-10	0	10
TE 5	0.5	45	4.00	5.11	6.47	8.05	9.73	11.2
	01	45	7.33	9.39	11.9	14.8	17.9	20.6
	02	45	10.3	13.2	16.8	20.8	25.0	28.5
	03	45	12.8	16.4	20.8	26.0	31.6	36.3
	04	45	16.8	21.8	28.0	35.4	43.2	49.6
TE 12	05	45	17.5	22.8	29.6	38.1	47.8	57.3
	06	45	21.7	28.7	37.8	49.3	62.9	76.4
	07	45	27.4	35.3	46.1	60.1	77.1	95.0
TE 20	08	45	40.2	51.4	65.7	83.4	103	121
	09	45	42.2	54.3	70.2	90.6	115	139
TE 55	10	45	47.4	62.9	82.9	108	137	167
	11	45	51.6	68.4	90.0	117	149	181
	12	45	54.6	72.5	95.8	125	160	197
	13	45	64.3	85.8	114	150	193	236

Capacity in TR. Range: -40 – 50 °F.
Opening superheat sh = 7.2 °F.

US units R407A

Valve type	Orifice no.	Cond. temp. [°F]	Evap. temp. [°F]					
			-40	-20	0	20	40	50
TE 5	0.5	115	1.13	1.48	1.92	2.43	2.96	3.18
	01	115	2.06	2.72	3.53	4.48	5.44	5.85
	02	115	2.89	3.82	4.97	6.29	7.58	8.10
	03	115	3.60	4.74	6.17	7.86	9.58	10.3
	04	115	4.72	6.30	8.32	10.7	13.1	14.1
TE 12	05	115	4.92	6.58	8.78	11.6	14.7	16.2
	06	115	6.10	8.28	11.2	15.0	19.4	21.5
	07	115	7.67	10.2	13.6	18.3	23.8	26.6
TE 20	08	115	11.3	14.8	19.5	25.3	31.6	34.3
	09	115	11.8	15.6	20.8	27.5	35.5	39.2
TE 55	10	115	13.2	18.1	24.6	32.9	42.5	47.1
	11	115	14.4	19.7	26.7	35.7	46.0	50.9
	12	115	15.2	20.9	28.4	38.2	49.7	55.4
	13	115	17.9	24.6	33.8	45.7	59.6	66.5

Capacity in kW. Range: -40 – 10 °C.
Opening superheat sh = 4 K

SI units R407A

Valve type	Orifice no.	Cond. temp. [°C]	Evap. temp. [°C]					
			-40	-30	-20	-10	0	10
TE 5	0.5	55	3.65	4.66	5.91	7.42	9.12	10.83
	01	55	6.68	8.56	10.9	13.7	16.9	20.0
	02	55	9.34	12.0	15.4	19.4	23.8	27.9
	03	55	11.6	14.8	18.8	23.8	29.4	35.0
	04	55	15.0	19.5	25.2	32.3	40.3	48.2
TE 12	05	55	15.9	20.2	25.8	33.1	42.0	51.9
	06	55	19.4	25.1	32.7	42.6	55.0	69.1
	07	55	24.5	30.7	39.0	50.0	64.3	81.3
TE 20	08	55	35.6	45.1	57.4	73.2	92.5	113
	09	55	36.8	46.6	59.6	76.9	99.2	124
TE 55	10	55	39.3	52.7	70.3	93.0	121	152
	11	55	42.5	57.0	75.8	100	130	164
	12	55	44.6	59.8	79.9	106	139	176
	13	55	51.4	69.4	93.4	125	164	209

Capacity in TR. Range: -40 – 50 °F.
Opening superheat sh = 7.2 °F.

US units R407A

Valve type	Orifice no.	Cond. temp. [°F]	Evap. temp. [°F]					
			-40	-20	0	20	40	50
TE 5	0.5	135	1.01	1.32	1.72	2.21	2.75	3.02
	01	135	1.85	2.43	3.17	4.08	5.09	5.58
	02	135	2.58	3.42	4.49	5.77	7.16	7.81
	03	135	3.20	4.19	5.47	7.06	8.86	9.73
	04	135	4.13	5.52	7.34	9.63	12.2	13.4
TE 12	05	135	4.39	5.70	7.47	9.80	12.7	14.2
	06	135	5.34	7.08	9.46	12.7	16.7	19.0
	07	135	6.78	8.63	11.2	14.7	19.4	22.0
TE 20	08	135	9.80	12.7	16.6	21.7	27.9	31.2
	09	135	10.1	13.1	17.1	22.8	30.1	34.1
TE 55	10	135	10.6	14.7	20.3	27.8	37.0	41.9
	11	135	11.5	15.9	21.9	29.9	39.7	45.0
	12	135	12.0	16.7	23.0	31.6	42.3	48.2
	13	135	13.8	19.3	26.8	37.1	50.1	57.2

Subcooling correction factor, f_{sub}

Subcooling [K]	2	4	10	15	20	25	30
Correction factor	0.98	1.00	1.07	1.13	1.19	1.24	1.30

Subcooling correction factor, f_{sub}

Subcooling [°F]	2	7	10	20	30	40	50
Correction factor	0.97	1.00	1.02	1.09	1.16	1.23	1.29

Distributer correction factor, f_p

SI units R407A

Pressure drop [bar] Δp	Evap. temp. [°C]					
	-40	-30	-20	-10	0	10
0	1	1	1	1	1	1
1	0.96	0.96	0.96	0.96	0.95	0.94
1.5	0.95	0.94	0.94	0.93	0.92	0.90
2	0.93	0.92	0.92	0.91	0.89	0.87

Calculated at 32 °C condensing temperature.

Distributer correction factor, f_p

US units R407A

Pressure drop [psi] Δp	Evap. temp. [°F]					
	-40	-20	0	20	40	50
0	1	1	1	1	1	1
15	0.96	0.96	0.96	0.95	0.94	0.93
25	0.94	0.93	0.93	0.92	0.90	0.89
30	0.92	0.92	0.91	0.90	0.88	0.86

Calculated at 90 °F condensing temperature.

Data sheet | Thermostatic expansion valves, type TE 5 – TE 55

Capacity in kW. Range: -40 – 10 °C.
Opening superheat sh = 4 K

SI units R448A/R449A

Valve type	Orifice no.	Cond. temp. [°C]	Evap. temp. [°C]					
			-40	-30	-20	-10	0	10
TE 5	0.5	25	4.27	5.53	6.90	8.31	9.50	9.95
	01	25	7.84	10.2	12.7	15.3	17.4	18.1
	02	25	11.0	14.3	17.8	21.3	24.0	24.7
	03	25	13.9	18.0	22.6	27.2	31.1	32.2
	04	25	18.4	24.2	30.6	37.1	42.3	43.4
TE 12	05	25	22.5	29.0	36.5	44.8	52.5	56.1
	06	25	28.5	37.2	47.5	59.0	69.7	74.6
	07	25	37.4	48.4	61.8	77.3	92.3	100
TE 20	08	25	49.9	65.4	83.2	102	118	122
	09	25	54.0	71.7	93.3	118	140	147
TE 55	10	25	56.3	76.7	101	128	153	166
	11	25	62.0	84.4	111	141	168	181
	12	25	66.5	90.8	120	154	185	202
	13	25	80.7	112	148	189	228	246

Capacity in TR. Range: -40 – 50 °F.
Opening superheat sh = 7.2 °F.

US units R448A/R449A

Valve type	Orifice no.	Cond. temp. [°F]	Evap. temp. [°F]					
			-40	-20	0	20	40	50
TE 5	0.5	75	1.21	1.61	2.04	2.47	2.75	2.76
	01	75	2.23	2.96	3.75	4.52	5.02	5.02
	02	75	3.12	4.15	5.25	6.29	6.90	6.84
	03	75	3.93	5.26	6.70	8.09	8.96	8.93
	04	75	5.24	7.08	9.09	11.0	12.2	12.0
TE 12	05	75	6.40	8.47	10.9	13.5	15.4	15.6
	06	75	8.13	10.9	14.2	17.8	20.5	20.8
	07	75	10.7	14.2	18.6	23.5	27.4	28.0
TE 20	08	75	14.2	19.2	24.8	30.6	34.2	33.9
	09	75	15.4	21.2	28.2	35.8	41.0	40.9
TE 55	10	75	16.2	22.7	30.5	38.9	45.4	46.3
	11	75	17.8	24.9	33.6	42.8	49.7	50.6
	12	75	19.1	26.9	36.5	46.9	55.2	56.6
	13	75	23.2	32.9	44.8	57.8	67.6	68.6

Capacity in kW. Range: -40 – 10 °C.
Opening superheat sh = 4 K

SI units R448A/R449A

Valve type	Orifice no.	Cond. temp. [°C]	Evap. temp. [°C]					
			-40	-30	-20	-10	0	10
TE 5	0.5	35	4.22	5.50	6.96	8.54	10.1	11.4
	01	35	7.73	10.1	12.8	15.7	18.6	20.7
	02	35	10.8	14.2	18.0	22.0	25.9	28.5
	03	35	13.6	17.8	22.6	27.9	33.0	36.8
	04	35	17.9	23.8	30.6	38.0	45.2	50.1
TE 12	05	35	21.6	27.8	35.3	44.0	53.5	61.4
	06	35	27.1	35.4	45.6	57.7	70.9	82.1
	07	35	35.0	44.9	57.4	72.8	90.1	105
TE 20	08	35	47.2	62.2	80.1	101	122	137
	09	35	49.8	66.2	86.7	112	139	161
TE 55	10	35	51.1	70.5	94.4	123	153	179
	11	35	55.8	77.0	103	134	167	195
	12	35	59.4	82.1	111	144	182	215
	13	35	70.7	98.4	133	175	221	260

Capacity in TR. Range: -40 – 50 °F.
Opening superheat sh = 7.2 °F.

US units R448A/R449A

Valve type	Orifice no.	Cond. temp. [°F]	Evap. temp. [°F]					
			-40	-20	0	20	40	50
TE 5	0.5	95	1.20	1.61	2.07	2.58	3.05	3.22
	01	95	2.20	2.95	3.82	4.75	5.59	5.89
	02	95	3.07	4.15	5.36	6.64	7.74	8.09
	03	95	3.85	5.20	6.74	8.41	9.94	10.5
	04	95	5.08	6.96	9.13	11.5	13.6	14.2
TE 12	05	95	6.13	8.12	10.5	13.4	16.3	17.5
	06	95	7.70	10.3	13.7	17.6	21.7	23.3
	07	95	9.95	13.1	17.2	22.3	27.7	29.9
TE 20	08	95	13.4	18.2	24.0	30.6	36.9	38.9
	09	95	14.1	19.4	26.1	34.3	42.7	45.6
TE 55	10	95	14.5	20.7	28.5	37.7	47.0	50.9
	11	95	15.8	22.6	31.1	41.1	51.2	55.4
	12	95	16.9	24.1	33.4	44.5	56.1	61.0
	13	95	20.1	28.9	40.3	54.1	68.2	73.9

Subcooling correction factor, f_{sub}

Subcooling [K]	2	4	10	15	20	25	30
Correction factor	0.98	1.00	1.07	1.13	1.18	1.24	1.31

Subcooling correction factor, f_{sub}

Subcooling [°F]	2	7	10	20	30	40	50
Correction factor	0.97	1.00	1.02	1.08	1.15	1.21	1.28

Distributer correction factor, f_p

SI units R448A/R449A

Pressure drop [bar] Δp	Evap. temp. [°C]					
	-40	-30	-20	-10	0	10
	Correction factor					
0	1	1	1	1	1	1
1	0.96	0.96	0.96	0.96	0.95	0.94
1.5	0.95	0.94	0.94	0.93	0.92	0.90
2	0.93	0.92	0.92	0.91	0.90	0.87

* Calculated at 32 °C condensing temperature.

Distributer correction factor, f_p

US units R448A/R449A

Pressure drop [psi] Δp	Evap. temp. [°F]					
	-40	-20	0	20	40	50
	Correction factor					
0	1	1	1	1	1	1
15	0.96	0.96	0.96	0.95	0.94	0.94
25	0.94	0.93	0.93	0.92	0.90	0.89
30	0.93	0.92	0.92	0.90	0.88	0.87

Calculated at 90 °F condensing temperature.

Data sheet | Thermostatic expansion valves, type TE 5 – TE 55

Capacity in kW. Range: -40 – 10 °C.
Opening superheat sh = 4 K

SI units R448A/R449A

Valve type	Orifice no.	Cond. temp. [°C]	Evap. temp. [°C]					
			-40	-30	-20	-10	0	10
TE 5	0.5	45	4.07	5.34	6.79	8.42	10.2	11.8
	01	45	7.45	9.80	12.5	15.5	18.7	21.7
	02	45	10.4	13.8	17.6	21.9	26.2	30.0
	03	45	13.0	17.1	21.9	27.2	33.0	38.3
	04	45	16.9	22.7	29.4	37.1	45.3	52.6
TE 12	05	45	20.3	26.0	32.9	41.3	51.1	61.1
	06	45	25.2	32.8	42.2	53.7	67.5	81.9
	07	45	32.0	40.6	51.5	65.2	82.0	100
TE 20	08	45	43.6	57.6	74.5	94.7	117	139
	09	45	44.9	59.4	77.8	101	129	158
TE 55	10	45	45.1	62.8	85.0	112	142	174
	11	45	48.9	68.2	92.2	121	154	187
	12	45	51.6	72.1	97.9	129	166	204
	13	45	60.3	84.9	116	154	199	245

Capacity in TR. Range: -40 – 50 °F.
Opening superheat sh = 7.2 °F.

US units R448A/R449A

Valve type	Orifice no.	Cond. temp. [°F]	Evap. temp. [°F]					
			-40	-20	0	20	40	50
TE 5	0.5	115	1.15	1.55	2.02	2.54	3.09	3.35
	01	115	2.10	2.85	3.72	4.69	5.70	6.15
	02	115	2.94	4.00	5.23	6.60	7.96	8.54
	03	115	3.66	4.97	6.49	8.23	10.0	10.9
	04	115	4.77	6.59	8.75	11.2	13.8	14.9
TE 12	05	115	5.70	7.50	9.74	12.5	15.7	17.3
	06	115	7.07	9.47	12.5	16.3	20.8	23.1
	07	115	8.99	11.7	15.2	19.7	25.2	28.1
TE 20	08	115	12.3	16.7	22.1	28.7	36.0	39.3
	09	115	12.6	17.2	23.1	30.8	40.0	44.5
TE 55	10	115	12.6	18.2	25.4	34.1	44.0	48.9
	11	115	13.7	19.8	27.5	36.9	47.5	52.8
	12	115	14.4	20.9	29.2	39.5	51.3	57.3
	13	115	16.8	24.5	34.6	47.2	61.6	68.8

Capacity in kW. Range: -40 – 10 °C.
Opening superheat sh = 4 K

SI units R448A/R449A

Valve type	Orifice no.	Cond. temp. [°C]	Evap. temp. [°C]					
			-40	-30	-20	-10	0	10
TE 5	0.5	55	3.84	5.05	6.43	7.99	9.69	11.4
	01	55	7.01	9.26	11.8	14.8	17.9	21.1
	02	55	9.77	13.0	16.7	20.9	25.3	29.5
	03	55	12.1	16.0	20.5	25.6	31.2	36.8
	04	55	15.6	21.0	27.4	34.7	42.9	50.9
TE 12	05	55	18.6	23.6	29.7	37.1	45.9	55.9
	06	55	22.8	29.5	37.7	47.9	60.4	74.8
	07	55	28.7	35.8	44.7	56.0	70.3	87.3
TE 20	08	55	39.4	52.0	67.1	85.3	107	129
	09	55	39.7	52.1	67.7	87.6	113	142
TE 55	10	55	38.9	54.8	74.6	98.7	127	157
	11	55	42.0	59.1	80.3	106	136	169
	12	55	43.9	61.9	84.4	112	145	181
	13	55	50.3	71.5	98.4	132	171	215

Capacity in TR. Range: -40 – 50 °F.
Opening superheat sh = 7.2 °F.

US units R448A/R449A

Valve type	Orifice no.	Cond. temp. [°F]	Evap. temp. [°F]					
			-40	-20	0	20	40	50
TE 5	0.5	135	1.07	1.45	1.89	2.38	2.92	3.18
	01	135	1.96	2.66	3.48	4.41	5.41	5.89
	02	135	2.73	3.74	4.91	6.23	7.61	8.25
	03	135	3.38	4.60	6.01	7.63	9.38	10.3
	04	135	4.34	6.03	8.04	10.4	13.0	14.2
TE 12	05	135	5.16	6.71	8.62	11.0	13.8	15.4
	06	135	6.30	8.36	11.0	14.2	18.3	20.6
	07	135	7.92	10.08	12.9	16.5	21.1	23.8
TE 20	08	135	10.9	14.79	19.6	25.4	32.2	35.8
	09	135	10.9	14.73	19.6	26.0	34.2	38.8
TE 55	10	135	10.7	15.58	21.9	29.6	38.6	43.4
	11	135	11.5	16.77	23.5	31.8	41.4	46.5
	12	135	12.0	17.54	24.7	33.6	44.1	49.8
	13	135	13.7	20.20	28.7	39.4	52.1	58.9

Subcooling correction factor, f_{sub}

Subcooling [K]	2	4	10	15	20	25	30
Correction factor	0.98	1.00	1.07	1.13	1.18	1.24	1.31

Subcooling correction factor, f_{sub}

Subcooling [°F]	2	7	10	20	30	40	50
Correction factor	0.97	1.00	1.02	1.08	1.15	1.21	1.28

Distributer correction factor, f_p^*

SI units R448A/R449A

Pressure drop [bar] Δp	Evap. temp. [°C]					
	-40	-30	-20	-10	0	10
	Correction factor					
0	1	1	1	1	1	1
1	0.96	0.96	0.96	0.96	0.95	0.94
1.5	0.95	0.94	0.94	0.93	0.92	0.90
2	0.93	0.92	0.92	0.91	0.90	0.87

* Calculated at 32 °C condensing temperature.

Distributer correction factor, f_p^*

US units R448A/R449A

Pressure drop [psi] Δp	Evap. temp. [°F]					
	-40	-20	0	20	40	50
	Correction factor					
0	1	1	1	1	1	1
15	0.96	0.96	0.96	0.95	0.94	0.94
25	0.94	0.93	0.93	0.92	0.90	0.89
30	0.93	0.92	0.92	0.90	0.88	0.87

* Calculated at 90 °F condensing temperature.

Data sheet | Thermostatic expansion valves, type TE 5 – TE 55

Capacity in kW. Range: -60 – -25 °C.
Opening superheat sh = 4 K

SI units **R448A/
R449A**

Valve type	Orifice no.	Cond. temp. [°C]	Evap. temp. [°C]				
			-60	-50	-40	-30	-25
TE 5	0.5	20	2.57	3.35	4.33	5.53	6.18
	01	20	4.67	6.11	7.94	10.2	11.4
	02	20	6.51	8.54	11.1	14.2	15.9
	03	20	8.03	10.7	14.0	18.2	20.5
	04	20	10.4	14.0	18.6	24.4	27.7

Capacity in TR. Range: -75 – -15 °F.
Opening superheat sh = 7.2 °F.

US units **R448A/
R449A**

Valve type	Orifice no.	Cond. temp. [°F]	Evap. temp. [°F]				
			-75	-60	-45	-30	-15
TE 5	0.5	65	0.74	0.92	1.14	1.41	1.70
	01	65	1.34	1.68	2.09	2.58	3.13
	02	65	1.87	2.35	2.93	3.62	4.39
	03	65	2.31	2.93	3.70	4.61	5.64
	04	65	3.01	3.85	4.90	6.16	7.62

Capacity in kW. Range: -60 – -25 °C.
Opening superheat sh = 4 K

SI units **R448A/
R449A**

Valve type	Orifice no.	Cond. temp. [°C]	Evap. temp. [°C]				
			-60	-50	-40	-30	-25
TE 5	0.5	30	2.56	3.34	4.34	5.59	6.29
	01	30	4.64	6.08	7.94	10.3	11.6
	02	30	6.44	8.47	11.1	14.4	16.3
	03	30	8.0	10.6	13.9	18.2	20.6
	04	30	10.3	13.7	18.3	24.2	27.7

Capacity in TR. Range: -75 – -15 °F.
Opening superheat sh = 7.2 °F.

US units **R448A/
R449A**

Valve type	Orifice no.	Cond. temp. [°F]	Evap. temp. [°F]				
			-75	-60	-45	-30	-15
TE 5	0.5	85	0.74	0.92	1.15	1.42	1.74
	01	85	1.34	1.68	2.10	2.61	3.20
	02	85	1.86	2.34	2.93	3.65	4.49
	03	85	2.31	2.92	3.67	4.60	5.70
	04	85	2.97	3.78	4.81	6.09	7.66

Capacity in kW. Range: -60 – -25 °C.
Opening superheat sh = 4 K

SI units **R448A/
R449A**

Valve type	Orifice no.	Cond. temp. [°C]	Evap. temp. [°C]				
			-60	-50	-40	-30	-25
TE 5	0.5	40	2.50	3.25	4.23	5.46	6.17
	01	40	4.51	5.90	7.71	10.0	11.3
	02	40	6.24	8.19	10.8	14.1	15.9
	03	40	7.80	10.2	13.4	17.5	19.9
	04	40	9.91	13.1	17.4	23.1	26.6

Capacity in TR. Range: -75 – -15 °F.
Opening superheat sh = 7.2 °F.

US units **R448A/
R449A**

Valve type	Orifice no.	Cond. temp. [°F]	Evap. temp. [°F]				
			-75	-60	-45	-30	-15
TE 5	0.5	105	0.72	0.89	1.11	1.38	1.70
	01	105	1.30	1.62	2.03	2.53	3.13
	02	105	1.79	2.25	2.83	3.54	4.40
	03	105	2.24	2.81	3.52	4.41	5.48
	04	105	2.85	3.59	4.55	5.77	7.29

Capacity in kW. Range: -60 – -25 °C.
Opening superheat sh = 4 K

SI units **R448A/
R449A**

Valve type	Orifice no.	Cond. temp. [°C]	Evap. temp. [°C]				
			-60	-50	-40	-30	-25
TE 5	0.5	50	2.39	3.09	4.01	5.17	5.85
	01	50	4.29	5.59	7.30	9.48	10.7
	02	50	5.91	7.74	10.2	13.3	15.1
	03	50	7.46	9.67	12.6	16.3	18.5
	04	50	9.37	12.2	16.1	21.3	24.5

Capacity in TR. Range: -75 – -15 °F.
Opening superheat sh = 7.2 °F.

US units **R448A/
R449A**

Valve type	Orifice no.	Cond. temp. [°F]	Evap. temp. [°F]				
			-75	-60	-45	-30	-15
TE 5	0.5	125	0.68	0.84	1.05	1.30	1.60
	01	125	1.22	1.52	1.90	2.37	2.93
	02	125	1.68	2.11	2.64	3.31	4.12
	03	125	2.13	2.63	3.27	4.06	5.03
	04	125	2.67	3.33	4.17	5.25	6.62

Subcooling correction factor, f_{sub}

Subcooling [K]	2	4	10	15	20	25	30
Correction factor	0.97	1.00	1.08	1.14	1.20	1.27	1.33

Subcooling correction factor, f_{sub}

Subcooling [°F]	2	7	10	20	30	40	50
Correction factor	0.97	1.00	1.02	1.09	1.15	1.22	1.30

Distributer correction factor, f_p^*

SI units **R448A/R449A**

Pressure drop [bar] Δp	Evap. temp. [°C]				
	-60	-50	-40	-30	-25
	Correction factor				
0	1	1	1	1	1
1	0.97	0.97	0.96	0.96	0.96
1.5	0.95	0.95	0.95	0.94	0.94
2	0.93	0.93	0.93	0.92	0.92

* Calculated at 32 °C condensing temperature.

Distributer correction factor, f_p^*

US units **R448A/R449A**

Pressure drop [psi] Δp	Evap. temp. [°F]				
	-75	-60	-45	-30	-15
	Correction factor				
0	1	1	1	1	1
15	0.96	0.96	0.96	0.96	0.96
25	0.94	0.94	0.94	0.94	0.93
30	0.93	0.93	0.93	0.92	0.92

* Calculated at 90 °F condensing temperature.

Data sheet | Thermostatic expansion valves, type TE 5 – TE 55

Capacity in kW. Range: -40 – 10 °C.
Opening superheat sh = 4 K

SI units R452A

Valve type	Orifice no.	Cond. temp. [°C]	Evap. temp. [°C]					
			-40	-30	-20	-10	0	10
TE 5	0.5	25	3.60	4.78	6.04	7.27	8.23	8.41
	01	25	6.62	8.78	11.1	13.3	15.0	15.2
	02	25	9.28	12.3	15.5	18.5	20.6	20.6
	03	25	11.7	15.6	19.8	23.8	26.7	26.9
TE 12	04	25	15.5	21.0	26.8	32.4	36.3	36.1
	05	25	18.2	25.2	33.1	41.4	48.4	49.9
	06	25	23.0	32.3	43.2	54.8	64.5	66.5
TE 20	07	25	29.8	41.0	54.7	70.6	85.0	88.8
	08	25	32.4	44.4	58.1	72.6	84.4	86.8
TE 55	09	25	35.3	49.3	66.0	84.6	101	105
	10	25	44.1	59.5	78.1	98.7	117	125
	11	25	48.6	65.6	86.1	109	129	137
	12	25	52.4	70.9	93.6	119	143	153
	13	25	64.0	87.2	115	147	176	186

Capacity in TR. Range: -40 – 50 °F.
Opening superheat sh = 7.2 °F.

US units R452A

Valve type	Orifice no.	Cond. temp. [°F]	Evap. temp. [°F]					
			-40	-20	0	20	40	50
TE 5	0.5	75	1.03	1.40	1.79	2.16	2.36	2.33
	01	75	1.89	2.57	3.29	3.95	4.30	4.22
	02	75	2.65	3.61	4.60	5.47	5.87	5.72
	03	75	3.32	4.56	5.87	7.05	7.63	7.46
TE 12	04	75	4.43	6.16	7.98	9.60	10.3	10.0
	05	75	5.22	7.44	9.97	12.5	14.1	13.9
	06	75	6.59	9.57	13.1	16.6	18.7	18.5
TE 20	07	75	8.55	12.2	16.7	21.6	25.0	24.8
	08	75	9.25	13.1	17.5	21.8	24.4	24.1
TE 55	09	75	10.1	14.6	20.0	25.8	29.5	29.3
	10	75	12.6	17.6	23.6	29.9	34.5	34.8
	11	75	14.0	19.4	26.0	33.0	37.9	38.1
	12	75	15.1	21.0	28.3	36.3	42.2	42.7
	13	75	18.4	25.9	35.0	44.9	51.8	52.0

Capacity in kW. Range: -40 – 10 °C.
Opening superheat sh = 4 K

SI units R452A

Valve type	Orifice no.	Cond. temp. [°C]	Evap. temp. [°C]					
			-40	-30	-20	-10	0	10
TE 5	0.5	35	3.40	4.58	5.89	7.30	8.64	9.57
	01	35	6.24	8.43	10.9	13.4	15.8	17.4
	02	35	8.75	11.9	15.3	18.8	21.9	23.8
	03	35	10.9	14.8	19.1	23.7	28.0	30.8
TE 12	04	35	14.4	19.8	26.0	32.4	38.3	41.7
	05	35	16.6	23.1	30.6	39.3	48.3	55.1
	06	35	20.7	29.3	39.7	51.8	64.5	74.0
TE 20	07	35	26.2	36.1	48.5	63.8	81.1	94.9
	08	35	29.7	41.0	54.6	70.0	85.9	97.3
TE 55	09	35	31.6	44.3	59.9	78.8	99.4	115
	10	35	38.9	53.5	71.8	93.5	117	136
	11	35	42.6	58.6	78.6	102	128	148
	12	35	45.5	62.8	84.6	111	139	164
	13	35	54.7	75.9	103	135	170	199

Capacity in TR. Range: -40 – 50 °F.
Opening superheat sh = 7.2 °F.

US units R452A

Valve type	Orifice no.	Cond. temp. [°F]	Evap. temp. [°F]					
			-40	-20	0	20	40	50
TE 5	0.5	95	0.96	1.34	1.76	2.20	2.59	2.72
	01	95	1.77	2.46	3.24	4.05	4.74	4.95
	02	95	2.48	3.47	4.55	5.65	6.53	6.76
	03	95	3.09	4.33	5.72	7.17	8.39	8.73
TE 12	04	95	4.08	5.81	7.77	9.81	11.4	11.8
	05	95	4.71	6.77	9.22	12.0	14.7	15.7
	06	95	5.88	8.63	12.0	15.9	19.7	21.0
TE 20	07	95	7.44	10.6	14.6	19.7	25.0	26.9
	08	95	8.42	12.0	16.4	21.4	26.1	27.6
TE 55	09	95	8.98	13.0	18.1	24.3	30.6	32.8
	10	95	11.0	15.7	21.7	28.7	35.8	38.6
	11	95	12.1	17.2	23.7	31.5	39.1	42.0
	12	95	12.9	18.4	25.6	34.2	43.0	46.5
	13	95	15.5	22.3	31.1	41.7	52.4	56.4

Subcooling correction factor, f_{sub}

Subcooling [K]	2	4	10	15	20	25	30
Correction factor	0.97	1.00	1.08	1.15	1.22	1.29	1.38

Subcooling correction factor, f_{sub}

Subcooling [°F]	2	7	10	20	30	40	50
Correction factor	0.96	1.00	1.02	1.10	1.18	1.25	1.34

Distributer correction factor, f_p

SI units R452A

Pressure drop [bar] Δp	Evap. temp. [°C]					
	-40	-30	-20	-10	0	10
	Correction factor					
0	1	1	1	1	1	1
1	0.96	0.96	0.96	0.96	0.95	0.94
1.5	0.95	0.94	0.94	0.93	0.92	0.90
2	0.93	0.92	0.92	0.91	0.90	0.87

Calculated at 32 °C condensing temperature.

Distributer correction factor, f_p

US units R452A

Pressure drop [psi] Δp	Evap. temp. [°F]					
	-40	-20	0	20	40	50
	Correction factor					
0	1	1	1	1	1	1
15	0.96	0.96	0.96	0.95	0.94	0.93
25	0.94	0.94	0.93	0.92	0.90	0.89
30	0.93	0.92	0.92	0.90	0.88	0.86

Calculated at 90 °F condensing temperature.

Data sheet | Thermostatic expansion valves, type TE 5 – TE 55

Capacity in kW. Range: -40 – 10 °C.
Opening superheat sh = 4 K

SI units R452A

Valve type	Orifice no.	Cond. temp. [°C]	Evap. temp. [°C]					
			-40	-30	-20	-10	0	10
TE 5	0.5	45	3.09	4.22	5.49	6.91	8.38	9.72
	01	45	5.66	7.76	10.1	12.8	15.5	17.8
	02	45	7.94	10.9	14.3	17.9	21.6	24.6
	03	45	9.80	13.5	17.7	22.3	27.1	31.3
	04	45	12.8	18.0	23.9	30.6	37.3	42.9
TE 12	05	45	14.7	20.4	27.1	35.1	44.1	53.2
	06	45	18.1	25.7	34.8	45.9	58.8	71.8
	07	45	22.6	30.8	41.2	54.3	70.5	87.6
TE 20	08	45	26.3	36.5	48.8	63.5	80.1	96.1
	09	45	27.5	38.5	52.1	69.0	89.3	110
TE 55	10	45	32.7	45.8	62.5	83.0	107	130
	11	45	35.6	49.9	68.0	90.3	116	141
	12	45	37.8	53.0	72.4	96.7	125	154
	13	45	44.6	62.9	86.5	116	151	186

Capacity in TR. Range: -40 – 50 °F.
Opening superheat sh = 7.2 °F.

US units R452A

Valve type	Orifice no.	Cond. temp. [°F]	Evap. temp. [°F]					
			-40	-20	0	20	40	50
TE 5	0.5	115	0.86	1.22	1.63	2.08	2.54	2.75
	01	115	1.58	2.25	3.01	3.84	4.68	5.04
	02	115	2.22	3.17	4.24	5.40	6.51	6.95
	03	115	2.74	3.90	5.24	6.72	8.22	8.85
	04	115	3.58	5.21	7.11	9.23	11.3	12.1
TE 12	05	115	4.10	5.88	8.03	10.6	13.5	14.9
	06	115	5.05	7.42	10.4	14.0	18.1	20.2
	07	115	6.28	8.87	12.2	16.5	21.8	24.5
TE 20	08	115	7.35	10.6	14.5	19.3	24.6	27.0
	09	115	7.68	11.1	15.5	21.0	27.7	31.0
TE 55	10	115	9.07	13.2	18.6	25.3	32.9	36.6
	11	115	9.87	14.4	20.2	27.5	35.7	39.7
	12	115	10.5	15.2	21.5	29.5	38.7	43.2
	13	115	12.3	18.1	25.7	35.4	46.7	52.1

Capacity in kW. Range: -40 – 10 °C.
Opening superheat sh = 4 K

SI units R452A

Valve type	Orifice no.	Cond. temp. [°C]	Evap. temp. [°C]					
			-40	-30	-20	-10	0	10
TE 5	0.5	55	2.70	3.73	4.89	6.19	7.59	8.97
	01	55	4.94	6.87	9.05	11.5	14.1	16.6
	02	55	6.92	9.70	12.8	16.2	19.8	23.1
	03	55	8.49	11.8	15.6	19.8	24.4	28.8
	04	55	11.0	15.6	21.0	27.1	33.7	40.0
TE 12	05	55	12.6	17.5	23.1	29.6	37.3	45.7
	06	55	15.4	21.7	29.3	38.5	49.5	61.8
	07	55	18.9	25.7	33.9	44.0	56.7	71.5
TE 20	08	55	22.6	31.4	41.9	54.4	69.1	85.0
	09	55	23.3	32.4	43.5	57.3	74.3	94.0
TE 55	10	55	26.1	37.3	51.6	69.4	90.7	114
	11	55	28.2	40.4	55.8	75.0	97.8	123
	12	55	29.6	42.4	58.8	79.5	104	132
	13	55	34.3	49.5	69.1	93.9	124	158

Capacity in TR. Range: -40 – 50 °F.
Opening superheat sh = 7.2 °F.

US units R452A

Valve type	Orifice no.	Cond. temp. [°F]	Evap. temp. [°F]					
			-40	-20	0	20	40	50
TE 5	0.5	135	0.74	1.06	1.42	1.83	2.26	2.47
	01	135	1.35	1.95	2.63	3.39	4.19	4.57
	02	135	1.89	2.75	3.73	4.80	5.88	6.37
	03	135	2.32	3.35	4.53	5.85	7.25	7.93
	04	135	2.98	4.43	6.11	8.04	10.1	11.0
TE 12	05	135	3.44	4.92	6.65	8.70	11.1	12.4
	06	135	4.18	6.13	8.48	11.4	14.8	16.7
	07	135	5.15	7.18	9.70	12.9	16.9	19.1
TE 20	08	135	6.17	8.87	12.1	16.1	20.7	23.1
	09	135	6.35	9.11	12.5	16.9	22.3	25.4
TE 55	10	135	6.97	10.4	14.9	20.6	27.4	31.0
	11	135	7.53	11.3	16.1	22.2	29.5	33.3
	12	135	7.89	11.8	17.0	23.6	31.5	35.8
	13	135	9.08	13.7	19.8	27.8	37.5	42.6

Subcooling correction factor, f_{sub}

Subcooling [K]	2	4	10	15	20	25	30
Correction factor	0.97	1.00	1.08	1.15	1.22	1.29	1.38

Subcooling correction factor, f_{sub}

Subcooling [°F]	2	7	10	20	30	40	50
Correction factor	0.96	1.00	1.02	1.10	1.18	1.25	1.34

Distributer correction factor, f_p

SI units R452A

Pressure drop [bar] Δp	Evap. temp. [°C]					
	-40	-30	-20	-10	0	10
	Correction factor					
0	1	1	1	1	1	1
1	0.96	0.96	0.96	0.96	0.95	0.94
1.5	0.95	0.94	0.94	0.93	0.92	0.90
2	0.93	0.92	0.92	0.91	0.90	0.87

Calculated at 32 °C condensing temperature.

Distributer correction factor, f_p

US units R452A

Pressure drop [psi] Δp	Evap. temp. [°F]					
	-40	-20	0	20	40	50
	Correction factor					
0	1	1	1	1	1	1
15	0.96	0.96	0.96	0.95	0.94	0.93
25	0.94	0.94	0.93	0.92	0.90	0.89
30	0.93	0.92	0.92	0.90	0.88	0.86

Calculated at 90 °F condensing temperature.

Data sheet | Thermostatic expansion valves, type TE 5 – TE 55

Capacity in kW. Range: -60 – -25 °C.
Opening superheat sh = 4 K

SI units R452A

Valve type	Orifice no.	Cond. temp. [°C]	Evap. temp. [°C]				
			-60	-50	-40	-30	-25
TE 5	0.5	20	1.95	2.58	3.37	4.32	4.81
	01	20	3.56	4.72	6.19	7.93	8.85
	02	20	4.96	6.59	8.68	11.1	12.4
	03	20	6.13	8.27	11.0	14.2	15.9
	04	20	8.03	10.9	14.7	19.2	21.6

Capacity in TR. Range: -75 – -15 °F.
Opening superheat sh = 7.2 °F.

US units R452A

Valve type	Orifice no.	Cond. temp. [°F]	Evap. temp. [°F]				
			-75	-60	-45	-30	-15
TE 5	0.5	65	0.56	0.71	0.89	1.10	1.33
	01	65	1.03	1.30	1.64	2.02	2.44
	02	65	1.44	1.82	2.29	2.84	3.43
	03	65	1.78	2.28	2.90	3.63	4.41
	04	65	2.33	3.01	3.86	4.88	5.98

Capacity in kW. Range: -60 – -25 °C.
Opening superheat sh = 4 K

SI units R452A

Valve type	Orifice no.	Cond. temp. [°C]	Evap. temp. [°C]				
			-60	-50	-40	-30	-25
TE 5	0.5	30	1.86	2.48	3.28	4.27	4.80
	01	30	3.39	4.53	6.02	7.84	8.83
	02	30	4.70	6.31	8.42	11.0	12.4
	03	30	5.81	7.85	10.6	13.9	15.7
	04	30	7.52	10.3	14.0	18.6	21.2

Capacity in TR. Range: -75 – -15 °F.
Opening superheat sh = 7.2 °F.

US units R452A

Valve type	Orifice no.	Cond. temp. [°F]	Evap. temp. [°F]				
			-75	-60	-45	-30	-15
TE 5	0.5	85	0.54	0.68	0.87	1.08	1.33
	01	85	0.98	1.25	1.58	1.99	2.45
	02	85	1.36	1.74	2.21	2.79	3.43
	03	85	1.68	2.16	2.78	3.52	4.35
	04	85	2.18	2.82	3.66	4.68	5.87

Capacity in kW. Range: -60 – -25 °C.
Opening superheat sh = 4 K

SI units R452A

Valve type	Orifice no.	Cond. temp. [°C]	Evap. temp. [°C]				
			-60	-50	-40	-30	-25
TE 5	0.5	40	1.70	2.28	3.05	4.01	4.55
	01	40	3.09	4.16	5.58	7.37	8.36
	02	40	4.27	5.78	7.80	10.3	11.7
	03	40	5.30	7.15	9.67	12.9	14.7
	04	40	6.78	9.24	12.6	17.1	19.6

Capacity in TR. Range: -75 – -15 °F.
Opening superheat sh = 7.2 °F.

US units R452A

Valve type	Orifice no.	Cond. temp. [°F]	Evap. temp. [°F]				
			-75	-60	-45	-30	-15
TE 5	0.5	105	0.49	0.62	0.80	1.01	1.25
	01	105	0.89	1.13	1.45	1.84	2.30
	02	105	1.22	1.57	2.03	2.58	3.23
	03	105	1.52	1.95	2.51	3.21	4.02
	04	105	1.94	2.51	3.27	4.23	5.37

Capacity in kW. Range: -60 – -25 °C.
Opening superheat sh = 4 K

SI units R452A

Valve type	Orifice no.	Cond. temp. [°C]	Evap. temp. [°C]				
			-60	-50	-40	-30	-25
TE 5	0.5	50	1.49	2.0	2.70	3.58	4.07
	01	50	2.69	3.64	4.93	6.56	7.48
	02	50	3.71	5.04	6.86	9.20	10.5
	03	50	4.63	6.22	8.43	11.3	12.9
	04	50	5.86	7.94	10.9	14.8	17.1

Capacity in TR. Range: -75 – -15 °F.
Opening superheat sh = 7.2 °F.

US units R452A

Valve type	Orifice no.	Cond. temp. [°F]	Evap. temp. [°F]				
			-75	-60	-45	-30	-15
TE 5	0.5	125	0.42	0.54	0.69	0.88	1.10
	01	125	0.75	0.97	1.25	1.60	2.01
	02	125	1.04	1.34	1.74	2.24	2.83
	03	125	1.30	1.66	2.14	2.74	3.46
	04	125	1.64	2.11	2.74	3.56	4.57

Subcooling correction factor, f_{sub}

Subcooling [K]	2	4	10	15	20	25	30
Correction factor	0.97	1.00	1.10	1.17	1.25	1.33	1.41

Subcooling correction factor, f_{sub}

Subcooling [°F]	2	7	10	20	30	40	50
Correction factor	0.96	1.00	1.02	1.10	1.18	1.26	1.37

Distributer correction factor, f_p^*

SI units R452A

Pressure drop [bar] Δp	Evap. temp. [°C]				
	-60	-50	-40	-30	-25
	Correction factor				
0	1	1	1	1	1
1	0.97	0.97	0.96	0.96	0.96
1.5	0.95	0.95	0.95	0.94	0.94
2	0.93	0.93	0.93	0.93	0.92

* Calculated at 32 °C condensing temperature.

Distributer correction factor, f_p^*

US units R452A

Pressure drop [psi] Δp	Evap. temp. [°F]				
	-75	-60	-45	-30	-15
	Correction factor				
0	1	1	1	1	1
15	0.97	0.97	0.96	0.96	0.96
25	0.94	0.94	0.94	0.94	0.93
30	0.93	0.93	0.93	0.92	0.92

* Calculated at 90 °F condensing temperature.

Data sheet | Thermostatic expansion valves, type TE 5 – TE 55

Capacity in kW. Range: -40 – 10 °C.
Opening superheat sh = 4 K

SI units R404A/R507

Valve type	Orifice no.	Cond. temp. [°C]	Evap. temp. [°C]					
			-40	-30	-20	-10	0	10
TE 5	0.5	25	3.68	4.77	5.91	6.93	7.54	7.30
	01	25	6.76	8.76	10.8	12.7	13.7	13.2
	02	25	9.49	12.3	15.1	17.6	18.8	17.9
	03	25	12.0	15.6	19.4	22.6	24.4	23.3
TE 12	04	25	16.1	21.1	26.3	30.8	33.1	31.2
	05	25	20.7	28.0	36.0	43.9	48.9	47.2
	06	25	24.9	34.1	44.5	55.0	61.7	59.6
TE 20	07	25	32.5	43.9	57.6	71.9	81.4	78.3
	08	25	35.7	48.4	62.2	75.2	82.9	79.7
TE 55	09	25	39.5	54.2	71.3	88.4	100	97.0
	10	25	46.5	64.9	86.1	108	124	125
	11	25	51.1	71.2	94.4	118	136	135
	12	25	54.8	76.8	103	130	151	152
	13	25	66.5	93.7	126	159	183	181

Capacity in TR. Range: -40 – 50 °F.
Opening superheat sh = 7.2 °F.

US units R404A/R507

Valve type	Orifice no.	Cond. temp. [°F]	Evap. temp. [°F]					
			-40	-20	0	20	40	50
TE 5	0.5	75	1.05	1.39	1.74	2.03	2.11	2.02
	01	75	1.93	2.56	3.20	3.70	3.83	3.65
	02	75	2.71	3.58	4.45	5.11	5.21	4.93
	03	75	3.42	4.56	5.71	6.61	6.78	6.43
TE 12	04	75	4.59	6.17	7.76	8.98	9.15	8.62
	05	75	5.94	8.23	10.8	13.0	13.8	13.1
	06	75	7.14	10.1	13.4	16.4	17.4	16.5
TE 20	07	75	9.36	13.1	17.4	21.6	22.9	21.7
	08	75	10.2	14.2	18.6	22.2	23.2	22.0
TE 55	09	75	11.3	16.1	21.5	26.4	28.2	26.8
	10	75	13.4	19.2	26.0	32.4	35.6	34.6
	11	75	14.7	21.1	28.5	35.5	38.8	37.5
	12	75	15.8	22.8	31.1	39.2	43.4	42.2
	13	75	19.2	27.9	38.2	47.9	52.3	50.3

Capacity in kW. Range: -40 – 10 °C.
Opening superheat sh = 4 K

SI units R404A/R507

Valve type	Orifice no.	Cond. temp. [°C]	Evap. temp. [°C]					
			-40	-30	-20	-10	0	10
TE 5	0.5	35	3.45	4.55	5.78	7.05	8.12	8.61
	01	35	6.34	8.37	10.6	12.9	14.8	15.6
	02	35	8.90	11.8	14.9	18.0	20.4	21.3
	03	35	11.1	14.8	18.8	22.9	26.3	28.0
TE 12	04	35	14.9	19.9	25.5	31.2	35.7	37.1
	05	35	18.7	25.3	33.3	42.3	50.5	54.4
	06	35	22.3	30.7	41.0	52.7	63.6	68.7
TE 20	07	35	27.8	37.9	50.7	66.0	81.2	89.1
	08	35	32.4	44.3	58.4	73.6	86.9	92.6
TE 55	09	35	34.9	48.2	64.6	83.5	101	110
	10	35	40.6	57.7	78.7	103	126	141
	11	35	44.3	62.9	85.7	112	137	153
	12	35	47.1	67.2	92.1	121	150	170
	13	35	56.0	80.5	110	146	181	203

Capacity in TR. Range: -40 – 50 °F.
Opening superheat sh = 7.2 °F.

US units R404A/R507

Valve type	Orifice no.	Cond. temp. [°F]	Evap. temp. [°F]					
			-40	-20	0	20	40	50
TE 5	0.5	95	0.98	1.33	1.72	2.11	2.39	2.44
	01	95	1.80	2.44	3.16	3.87	4.37	4.44
	02	95	2.53	3.43	4.42	5.37	5.98	6.04
	03	95	3.16	4.31	5.60	6.86	7.71	7.80
TE 12	04	95	4.21	5.81	7.60	9.34	10.5	10.5
	05	95	5.29	7.42	10.0	12.9	15.1	15.4
	06	95	6.32	9.02	12.4	16.1	19.0	19.5
TE 20	07	95	7.90	11.1	15.3	20.3	24.5	25.3
	08	95	9.18	13.0	17.5	22.3	25.8	26.3
TE 55	09	95	9.89	14.1	19.5	25.5	30.4	31.3
	10	95	11.5	17.0	23.8	31.5	38.3	40.1
	11	95	12.6	18.5	25.9	34.2	41.4	43.4
	12	95	13.4	19.8	27.9	37.2	45.7	48.2
	13	95	15.9	23.7	33.6	45.0	54.9	57.5

Subcooling correction factor, f_{sub}

Subcooling [K]	2	4	10	15	20	25	30
Correction factor	0.97	1.00	1.09	1.16	1.23	1.30	1.37

Subcooling correction factor, f_{sub}

Subcooling [°F]	2	7	10	20	30	40	50
Correction factor	0.96	1.00	1.03	1.11	1.20	1.28	1.37

Distributer correction factor, f_p

SI units R404A/R507

Pressure drop [bar] Δp	Evap. temp. [°C]					
	-40	-30	-20	-10	0	10
0	1	1	1	1	1	1
1	0.96	0.96	0.96	0.95	0.94	0.92
1.5	0.94	0.94	0.94	0.93	0.91	0.88
2	0.92	0.92	0.91	0.90	0.88	0.84

Calculated at 32 °C condensing temperature.

Distributer correction factor, f_p

US units R404A/R507

Pressure drop [psi] Δp	Evap. temp. [°F]					
	-40	-20	0	20	40	50
0	1	1	1	1	1	1
15	0.96	0.96	0.96	0.95	0.93	0.92
25	0.94	0.93	0.92	0.91	0.89	0.87
30	0.92	0.92	0.91	0.89	0.86	0.84

Calculated at 90 °F condensing temperature.

Data sheet | Thermostatic expansion valves, type TE 5 – TE 55

Capacity in kW. Range: -40 – 10 °C.

Opening superheat sh = 4 K

SI units R404A/R507

Valve type	Orifice no.	Cond. temp. [°C]	Evap. temp. [°C]					
			-40	-30	-20	-10	0	10
TE 5	0.5	45	3.08	4.11	5.32	6.67	8.02	9.05
	01	45	5.65	7.57	9.81	12.3	14.7	16.5
	02	45	7.94	10.7	13.8	17.2	20.4	22.7
	03	45	9.85	13.2	17.2	21.6	25.9	29.0
	04	45	13.0	17.7	23.3	29.4	35.4	39.4
TE 12	05	45	16.1	21.9	29.1	37.8	47.4	55.3
	06	45	19.1	26.4	35.6	46.9	59.6	70.1
	07	45	23.1	31.4	42.0	55.7	71.9	86.8
TE 20	08	45	28.0	38.4	51.3	66.6	82.8	95.2
	09	45	29.5	40.7	55.0	73.0	93.2	110
TE 55	10	45	33.5	48.5	67.4	90.6	117	140
	11	45	36.2	52.5	72.9	97.9	126	150
	12	45	38.3	55.5	77.5	104	136	165
	13	45	44.6	65.3	91.8	125	162	196

Capacity in TR. Range: -40 – 50 °F.

Opening superheat sh = 7.2 °F.

US units R404A/R507

Valve type	Orifice no.	Cond. temp. [°F]	Evap. temp. [°F]					
			-40	-20	0	20	40	50
TE 5	0.5	115	0.86	1.18	1.57	2.00	2.41	2.56
	01	115	1.58	2.18	2.90	3.69	4.42	4.69
	02	115	2.22	3.07	4.07	5.15	6.11	6.43
	03	115	2.75	3.81	5.07	6.48	7.77	8.21
	04	115	3.63	5.11	6.88	8.84	10.6	11.2
TE 12	05	115	4.48	6.29	8.60	11.4	14.4	15.6
	06	115	5.29	7.59	10.6	14.3	18.2	19.8
	07	115	6.41	8.97	12.4	16.9	22.1	24.3
TE 20	08	115	7.79	11.1	15.2	20.1	25.1	26.9
	09	115	8.19	11.7	16.3	22.2	28.5	31.1
TE 55	10	115	9.25	14.0	20.1	27.6	35.9	39.5
	11	115	10.0	15.1	21.7	29.8	38.6	42.4
	12	115	10.6	16.0	23.1	32.0	41.9	46.3
	13	115	12.3	18.6	27.3	38.0	49.9	55.1

Capacity in kW. Range: -40 – 10 °C.

Opening superheat sh = 4 K

SI units R404A/R507

Valve type	Orifice no.	Cond. temp. [°C]	Evap. temp. [°C]					
			-40	-30	-20	-10	0	10
TE 5	0.5	55	2.60	3.50	4.57	5.83	7.20	8.50
	01	55	4.76	6.44	8.45	10.8	13.3	15.7
	02	55	6.69	9.10	11.9	15.2	18.6	21.7
	03	55	8.24	11.1	14.6	18.7	23.2	27.3
	04	55	10.8	14.9	19.8	25.6	31.9	37.5
TE 12	05	55	13.3	16.0	23.8	31.1	40.0	49.4
	06	55	15.5	21.4	28.9	38.4	50.3	63.1
	07	55	18.6	24.9	33.0	43.4	56.9	72.4
TE 20	08	55	23.1	31.5	42.1	55.4	71.1	86.8
	09	55	23.8	32.6	43.9	58.6	77.2	97.3
TE 55	10	55	25.7	38.1	53.8	73.7	97.8	124
	11	55	27.7	41.0	57.8	79.0	105	132
	12	55	28.9	42.9	60.8	83.6	112	142
	13	55	33.1	49.6	70.7	97.9	131	168

Capacity in TR. Range: -40 – 50 °F.

Opening superheat sh = 7.2 °F.

US units R404A/R507

Valve type	Orifice no.	Cond. temp. [°F]	Evap. temp. [°F]					
			-40	-20	0	20	40	50
TE 5	0.5	135	0.70	0.98	1.31	1.71	2.14	2.34
	01	135	1.29	1.80	2.42	3.16	3.95	4.31
	02	135	1.81	2.55	3.43	4.45	5.52	5.98
	03	135	2.22	3.10	4.18	5.47	6.87	7.50
	04	135	2.90	4.14	5.67	7.50	9.47	10.3
TE 12	05	135	3.57	4.98	6.77	9.07	11.9	13.4
	06	135	4.15	5.93	8.24	11.3	15.1	17.1
	07	135	4.99	6.87	9.33	12.6	16.9	19.3
TE 20	08	135	6.21	8.76	12.0	16.2	21.2	23.7
	09	135	6.38	9.00	12.5	17.2	23.1	26.3
TE 55	10	135	6.78	10.5	15.4	21.8	29.5	33.5
	11	135	7.29	11.3	16.5	23.3	31.5	35.7
	12	135	7.61	11.8	17.4	24.6	33.6	38.4
	13	135	8.67	13.6	20.2	28.8	39.5	45.2

Subcooling correction factor, f_{sub}

Subcooling [K]	2	4	10	15	20	25	30
Correction factor	0.97	1.00	1.09	1.16	1.23	1.30	1.37

Subcooling correction factor, f_{sub}

Subcooling [°F]	2	7	10	20	30	40	50
Correction factor	0.96	1.00	1.03	1.11	1.20	1.28	1.37

Distributer correction factor, f_p

SI units R404A/R507

Pressure drop [bar] Δp	Evap. temp. [°C]					
	-40	-30	-20	-10	0	10
0	1	1	1	1	1	1
1	0.96	0.96	0.96	0.95	0.94	0.92
1.5	0.94	0.94	0.94	0.93	0.91	0.88
2	0.92	0.92	0.91	0.90	0.88	0.84

Calculated at 32 °C condensing temperature.

Distributer correction factor, f_p

US units R404A/R507

Pressure drop [psi] Δp	Evap. temp. [°C]					
	-40	-20	0	20	40	50
0	1	1	1	1	1	1
15	0.96	0.96	0.96	0.95	0.93	0.92
25	0.94	0.93	0.92	0.91	0.89	0.87
30	0.92	0.92	0.91	0.89	0.86	0.84

Calculated at 90 °F condensing temperature.

Data sheet | Thermostatic expansion valves, type TE 5 – TE 55

Capacity in kW. Range: -60 – -25 °C.
Opening superheat sh = 4 K

SI units R404A/R507

Valve type	Orifice no.	Cond. temp. [°C]	Evap. temp. [°C]				
			-60	-50	-40	-30	-25
TE 5	0.5	20	2.01	2.87	3.92	5.12	5.73
	01	20	3.66	5.25	7.21	9.41	10.5
	02	20	5.09	7.33	10.1	13.2	14.7
	03	20	6.38	9.22	12.8	16.8	18.8
	04	20	8.32	12.2	17.1	22.8	25.6
TE 12	05	20	10.3	14.7	20.5	27.3	30.8
	06	20	12.8	18.6	26.2	35.5	40.5
	07	20	16.5	24.0	33.9	46.1	52.6
TE 55	9B	20	20.6	29.2	40.1	52.4	58.5
	10	20	24.1	34.7	49.0	66.8	76.6
	11	20	26.6	38.4	54.1	73.8	84.6
	12	20	28.6	41.3	58.5	80.2	92.3
	13	20	34.7	50.5	71.9	99.2	114

Capacity in TR. Range: -75 – -15 °F.
Opening superheat sh = 7.2 °F.

US units R404A/R507

Valve type	Orifice no.	Cond. temp. [°F]	Evap. temp. [°F]				
			-75	-60	-45	-30	-15
TE 5	0.5	65	0.59	0.79	1.03	1.30	1.58
	01	65	1.07	1.44	1.89	2.39	2.91
	02	65	1.49	2.01	2.64	3.35	4.06
	03	65	1.87	2.53	3.34	4.25	5.19
	04	65	2.44	3.35	4.46	5.74	7.07
TE 12	05	65	3.01	4.06	5.36	6.87	8.52
	06	65	3.77	5.13	6.85	8.90	11.2
	07	65	4.87	6.63	8.87	11.6	14.6
TE 55	9B	65	6.04	8.08	10.6	13.4	16.3
	10	65	7.10	9.62	12.8	16.8	21.3
	11	65	7.84	10.6	14.2	18.5	23.5
	12	65	8.45	11.5	15.4	20.1	25.6
	13	65	10.3	14.1	18.9	24.9	31.9

Capacity in kW. Range: -60 – -25 °C.
Opening superheat sh = 4 K

SI units R404A/R507

Valve type	Orifice no.	Cond. temp. [°C]	Evap. temp. [°C]				
			-60	-50	-40	-30	-25
TE 5	0.5	30	1.88	2.72	3.79	5.04	5.72
	01	30	3.42	4.97	6.96	9.29	10.5
	02	30	4.72	6.93	9.76	13.1	14.8
	03	30	5.87	8.63	12.2	16.5	18.7
	04	30	7.54	11.3	16.2	22.3	25.5
TE 12	05	30	9.33	13.6	19.3	26.3	30.2
	06	30	11.4	16.9	24.4	33.9	39.3
	07	30	14.4	21.3	30.8	43.0	49.9
TE 55	9B	30	18.5	26.6	37.3	50.0	56.6
	10	30	21.2	31.0	44.3	61.7	71.7
	11	30	23.2	34.0	48.7	67.7	78.6
	12	30	24.8	36.3	52.1	72.8	84.8
	13	30	29.5	43.6	61.0	88.6	104

Capacity in TR. Range: -75 – -15 °F.
Opening superheat sh = 7.2 °F.

US units R404A/R507

Valve type	Orifice no.	Cond. temp. [°F]	Evap. temp. [°F]				
			-75	-60	-45	-30	-15
TE 5	0.5	85	0.55	0.75	0.99	1.27	1.58
	01	85	1.00	1.36	1.81	2.34	2.91
	02	85	1.38	1.90	2.54	3.29	4.09
	03	85	1.71	2.36	3.18	4.13	5.18
	04	85	2.20	3.08	4.20	5.55	7.06
TE 12	05	85	2.72	3.73	5.02	6.57	8.35
	06	85	3.34	4.63	6.30	8.39	10.9
	07	85	4.22	5.85	7.97	10.6	13.8
TE 55	9B	85	5.39	7.32	9.73	12.6	15.7
	10	85	6.18	8.49	11.5	15.3	19.8
	11	85	6.79	9.32	12.6	16.8	21.7
	12	85	7.25	9.97	13.5	18.0	23.5
	13	85	8.66	12.0	16.3	21.9	28.6

Subcooling correction factor, f_{sub}

Subcooling [K]	2	4	10	15	20	25	30
Correction factor	0.97	1.00	1.09	1.16	1.23	1.30	1.37

Subcooling correction factor, f_{sub}

Subcooling [°F]	2	7	10	20	30	40	50
Correction factor	0.96	1.00	1.03	1.11	1.20	1.28	1.37

Distributer correction factor, f_p

SI units R404A/R507

Pressure drop [bar] Δp	Evap. temp. [°C]				
	-60	-50	-40	-30	-25
	Correction factor				
0	1	1	1	1	1
1	0.97	0.96	0.96	0.96	0.96
1.5	0.95	0.95	0.94	0.94	0.94
2	0.93	0.93	0.92	0.92	0.92

Calculated at 32 °C condensing temperature.

Distributer correction factor, f_p

US units R404A/R507

Pressure drop [psi] Δp	Evap. temp. [°F]				
	-75	-60	-45	-30	-15
	Correction factor				
0	1	1	1	1	1
15	0.96	0.96	0.96	0.96	0.96
25	0.94	0.94	0.94	0.93	0.93
30	0.93	0.93	0.92	0.92	0.92

Calculated at 90 °F condensing temperature.

Data sheet | Thermostatic expansion valves, type TE 5 – TE 55

Capacity in kW. Range: -60 – -25 °C.
Opening superheat sh = 4 K

SI units R404A/R507

Valve type	Orifice no.	Cond. temp. [°C]	Evap. temp. [°C]				
			-60	-50	-40	-30	-25
TE 5	0.5	40	1.69	2.48	3.51	4.75	5.43
	01	40	3.06	4.53	6.44	8.76	10.0
	02	40	4.21	6.29	9.03	12.4	14.2
	03	40	5.17	7.75	11.2	15.4	17.7
	04	40	6.52	9.96	14.7	20.8	24.1
TE 12	05	40	8.10	12.0	17.4	24.2	28.0
	06	40	9.70	14.6	21.5	30.7	36.0
	07	40	12.0	18.1	26.6	37.9	44.6
TE 55	9B	40	15.8	23.1	33.0	45.1	51.8
	10	40	17.7	26.2	38.2	54.0	63.3
	11	40	19.2	28.6	41.6	58.8	68.9
	12	40	20.4	30.3	44.2	62.7	73.6
	13	40	23.8	35.7	52.3	74.8	88.3

Capacity in TR. Range: -75 – -15 °F.
Opening superheat sh = 7.2 °F.

US units R404A/R507

Valve type	Orifice no.	Cond. temp. [°F]	Evap. temp. [°F]				
			-75	-60	-45	-30	-15
TE 5	0.5	105	0.49	0.67	0.90	1.18	1.49
	01	105	0.88	1.22	1.65	2.17	2.75
	02	105	1.21	1.70	2.31	3.05	3.88
	03	105	1.49	2.09	2.86	3.80	4.86
	04	105	1.88	2.68	3.73	5.06	6.60
TE 12	05	105	2.33	3.25	4.43	5.91	7.66
	06	105	2.79	3.93	5.46	7.41	9.80
	07	105	3.44	4.84	6.72	9.13	12.1
TE 55	9B	105	4.52	6.23	8.43	11.1	14.2
	10	105	5.06	7.05	9.68	13.1	17.2
	11	105	5.51	7.68	10.6	14.2	18.7
	12	105	5.83	8.14	11.2	15.1	20.0
	13	105	6.81	9.56	13.2	18.0	23.9

Capacity in kW. Range: -60 – -25 °C.
Opening superheat sh = 4 K

SI units R404A/R507

Valve type	Orifice no.	Cond. temp. [°C]	Evap. temp. [°C]				
			-60	-50	-40	-30	-25
TE 5	0.5	50	1.47	2.18	3.13	4.29	4.95
	01	50	2.64	3.97	5.73	7.92	9.15
	02	50	3.61	5.50	8.04	11.2	13.0
	03	50	4.36	6.66	9.81	13.8	16.1
	04	50	5.35	8.39	12.7	18.4	21.7
TE 12	05	50	6.68	10.1	14.9	21.1	24.8
	06	50	7.75	12.0	18.1	26.3	31.2
	07	50	9.28	14.4	21.6	31.5	37.4
TE 55	9B	50	12.7	18.9	27.5	38.5	44.6
	10	50	13.8	21.0	31.1	44.7	52.8
	11	50	14.9	22.7	33.6	48.3	57.0
	12	50	15.6	23.8	35.4	51.0	60.3
	13	50	17.8	27.4	41.0	59.5	70.8

Capacity in TR. Range: -75 – -15 °F.
Opening superheat sh = 7.2 °F.

US units R404A/R507

Valve type	Orifice no.	Cond. temp. [°F]	Evap. temp. [°F]				
			-75	-60	-45	-30	-15
TE 5	0.5	125	0.41	0.58	0.79	1.04	1.33
	01	125	0.74	1.05	1.44	1.92	2.47
	02	125	1.02	1.45	2.01	2.70	3.50
	03	125	1.23	1.75	2.44	3.30	4.31
	04	125	1.50	2.19	3.13	4.34	5.81
TE 12	05	125	1.87	2.65	3.70	5.02	6.61
	06	125	2.15	3.12	4.42	6.13	8.27
	07	125	2.56	3.71	5.25	7.29	9.85
TE 55	9B	125	3.51	4.93	6.80	9.14	11.9
	10	125	3.81	5.43	7.60	10.4	13.9
	11	125	4.11	5.87	8.21	11.2	15.0
	12	125	4.30	6.15	8.61	11.8	15.9
	13	125	4.89	7.04	9.92	13.7	18.5

Subcooling correction factor, f_{sub}

Subcooling [K]	2	4	10	15	20	25	30
Correction factor	0.97	1.00	1.09	1.16	1.23	1.30	1.37

Subcooling correction factor, f_{sub}

Subcooling [°F]	2	7	10	20	30	40	50
Correction factor	0.96	1.00	1.03	1.11	1.20	1.28	1.37

Distributor correction factor, f_p

SI units R404A/R507

Pressure drop [bar] Δp	Evap. temp. [°C]				
	-60	-50	-40	-30	-25
0	1	1	1	1	1
1	0.97	0.96	0.96	0.96	0.96
1.5	0.95	0.95	0.94	0.94	0.94
2	0.93	0.93	0.92	0.92	0.92

Calculated at 32 °C condensing temperature.

Distributor correction factor, f_p

US units R404A/R507

Pressure drop [psi] Δp	Evap. temp. [°F]				
	-75	-60	-45	-30	-15
0	1	1	1	1	1
15	0.96	0.96	0.96	0.96	0.96
25	0.94	0.94	0.94	0.93	0.93
30	0.93	0.93	0.92	0.92	0.92

Calculated at 90 °F condensing temperature.

Data sheet | Thermostatic expansion valves, type TE 5 – TE 55

Capacity in kW. Range: -40 – 10 °C.
Opening superheat sh = 4 K

SI units R22

Valve type	Orifice no.	Cond. temp. [°C]	Evap. temp. [°C]					
			-40	-30	-20	-10	0	10
TE 5	0.5	25	4.53	5.73	7.00	8.17	8.87	8.56
	01	25	8.33	10.5	12.9	15.0	16.2	15.5
	02	25	11.7	14.8	18.0	20.8	22.3	21.2
	03	25	14.9	18.8	23.1	26.8	28.9	27.5
	04	25	19.9	25.5	31.4	36.6	39.3	37.0
TE 12	05	25	24.4	31.2	38.8	46.0	50.7	49.4
	06	25	31.4	40.5	50.8	60.9	67.5	65.7
	07	25	41.2	53.1	67.0	80.9	90.4	88.3
TE 20	08	25	54.5	70.9	88.6	104	113	105
	09	25	60.1	79.7	102	123	136	127
TE 55	10	25	65.5	86.3	110	133	150	149
	11	25	72.3	95.2	121	147	165	163
	12	25	78.1	103	132	161	183	183
	13	25	95.8	127	163	199	225	221

Capacity in TR. Range: -40 – 50 °F.
Opening superheat sh = 7.2 °F.

US units R22

Valve type	Orifice no.	Cond. temp. [°F]	Evap. temp. [°F]					
			-40	-20	0	20	40	50
TE 5	0.5	75	1.28	1.66	2.05	2.38	2.47	2.35
	01	75	2.35	3.05	3.77	4.35	4.49	4.26
	02	75	3.30	4.28	5.26	6.02	6.16	5.80
	03	75	4.20	5.45	6.76	7.80	8.01	7.56
	04	75	5.64	7.39	9.20	10.6	10.8	10.2
TE 12	05	75	6.93	9.08	11.4	13.5	14.2	13.6
	06	75	8.91	11.8	15.1	17.9	18.9	18.1
	07	75	11.7	15.5	19.9	24.0	25.5	24.4
TE 20	08	75	15.5	20.7	26.2	30.5	31.1	29.1
	09	75	17.1	23.4	30.4	36.4	37.6	35.1
TE 55	10	75	18.7	25.2	32.6	39.4	42.5	41.0
	11	75	20.6	27.9	36.0	43.4	46.6	44.8
	12	75	22.3	30.3	39.4	48.0	52.1	50.4
	13	75	27.4	37.4	48.8	59.3	63.6	60.8

Capacity in kW. Range: -40 – 10 °C.
Opening superheat sh = 4 K

SI units R22

Valve type	Orifice no.	Cond. temp. [°C]	Evap. temp. [°C]					
			-40	-30	-20	-10	0	10
TE 5	0.5	35	4.67	5.93	7.34	8.80	10.0	10.6
	01	35	8.56	10.9	13.5	16.2	18.4	19.3
	02	35	12.0	15.3	18.9	22.6	25.4	26.5
	03	35	15.2	19.3	24.0	28.8	32.7	34.2
	04	35	20.1	26.0	32.5	39.2	44.5	46.2
TE 12	05	35	24.6	31.2	39.0	47.6	55.3	59.5
	06	35	31.2	40.1	50.8	62.7	73.6	79.5
	07	35	40.3	51.3	64.7	80.1	95.0	103
TE 20	08	35	54.1	70.2	88.9	109	125	130
	09	35	58.0	76.4	98.7	124	146	155
TE 55	10	35	62.5	83.4	108	136	162	178
	11	35	68.6	91.4	118	149	177	194
	12	35	73.3	98.2	128	162	194	215
	13	35	88.3	119	156	197	237	260

Capacity in TR. Range: -40 – 50 °F.
Opening superheat sh = 7.2 °F.

US units R22

Valve type	Orifice no.	Cond. temp. [°F]	Evap. temp. [°F]					
			-40	-20	0	20	40	50
TE 5	0.5	95	1.33	1.73	2.18	2.63	2.96	3.02
	01	95	2.43	3.17	4.01	4.82	5.40	5.49
	02	95	3.41	4.46	5.61	6.71	7.44	7.51
	03	95	4.30	5.62	7.12	8.58	9.59	9.72
	04	95	5.72	7.57	9.67	11.7	13.0	13.1
TE 12	05	95	6.98	9.08	11.6	14.3	16.4	16.9
	06	95	8.85	11.7	15.1	18.9	21.9	22.6
	07	95	11.5	15.0	19.3	24.3	28.4	29.5
TE 20	08	95	15.4	20.5	26.5	32.6	36.6	36.9
	09	95	16.5	22.3	29.6	37.4	43.2	44.0
TE 55	10	95	17.8	24.4	32.5	41.2	48.5	50.6
	11	95	19.5	26.8	35.5	45.0	52.9	55.0
	12	95	20.8	28.8	38.4	49.1	58.5	61.2
	13	95	25.1	34.9	46.8	60.0	71.0	73.8

Subcooling correction factor, f_{sub}

Subcooling [K]	2	4	10	15	20	25	30
Correction factor	0.98	1.00	1.05	1.10	1.14	1.19	1.23

Subcooling correction factor, f_{sub}

Subcooling [°F]	2	7	10	20	30	40	50
Correction factor	0.97	1.00	1.02	1.07	1.12	1.17	1.22

Distributer correction factor, f_p

SI units R22

Pressure drop [bar] Δp	Evap. temp. [°C]					
	-40	-30	-20	-10	0	10
	Correction factor					
0	1	1	1	1	1	1
1	0.96	0.95	0.95	0.94	0.93	0.91
1.5	0.93	0.93	0.92	0.91	0.90	0.86
2	0.91	0.90	0.90	0.88	0.86	0.81

Calculated at 32 °C condensing temperature.

Distributer correction factor, f_p

US units R22

Pressure drop [psi] Δp	Evap. temp. [°F]					
	-40	-20	0	20	40	50
	Correction factor					
0	1	1	1	1	1	1
15	0.95	0.95	0.95	0.94	0.92	0.91
25	0.92	0.92	0.91	0.89	0.87	0.84
30	0.91	0.90	0.89	0.87	0.84	0.80

Calculated at 90 °F condensing temperature.

Data sheet | Thermostatic expansion valves, type TE 5 – TE 55

Capacity in kW. Range: -40 – 10 °C.
Opening superheat sh = 4 K

SI units R22

Valve type	Orifice no.	Cond. temp. [°C]	Evap. temp. [°C]					
			-40	-30	-20	-10	0	10
TE 5	0.5	45	4.71	5.98	7.45	9.06	10.6	11.8
	01	45	8.62	11.0	13.7	16.67	19.5	21.6
	02	45	12.1	15.4	19.3	23.4	27.2	29.8
	03	45	15.2	19.3	24.1	29.4	34.5	38.1
	04	45	20.0	25.7	32.6	40.1	47.1	51.9
TE 12	05	45	24.2	30.3	37.8	46.6	55.8	63.7
	06	45	30.3	38.6	48.9	61.1	74.2	85.3
	07	45	38.8	48.4	60.4	75.1	91.7	107
TE 20	08	45	52.6	67.8	86.0	107	127	142
	09	45	55.0	71.5	92.1	117	144	165
TE 55	10	45	58.0	78.1	102	132	163	190
	11	45	63.2	85.0	112	143	176	205
	12	45	67.0	90.4	119	154	191	225
	13	45	79.1	107	143	185.	231	271

Capacity in TR. Range: -40 – 50 °F.
Opening superheat sh = 7.2 °F.

US units R22

Valve type	Orifice no.	Cond. temp. [°F]	Evap. temp. [°F]					
			-40	-20	0	20	40	50
TE 5	0.5	115	1.34	1.74	2.22	2.73	3.21	3.39
	01	115	2.45	3.20	4.08	5.03	5.88	6.19
	02	115	3.42	4.50	5.74	7.04	8.16	8.53
	03	115	4.30	5.61	7.17	8.85	10.4	10.9
	04	115	5.65	7.50	9.70	12.1	14.2	14.8
TE 12	05	115	6.85	8.79	11.2	14.0	16.9	18.1
	06	115	8.58	11.2	14.5	18.5	22.6	24.3
	07	115	11.0	14.0	17.8	22.7	27.9	30.3
TE 20	08	115	14.9	19.7	25.5	32.2	38.4	40.6
	09	115	15.5	20.7	27.4	35.5	43.8	47.0
TE 55	10	115	16.3	22.7	30.7	40.1	49.8	53.9
	11	115	17.8	24.7	33.3	43.5	53.9	58.3
	12	115	18.8	26.2	35.6	46.9	58.7	63.9
	13	115	22.2	31.2	42.6	56.4	70.7	76.8

Capacity in kW. Range: -40 – 10 °C.
Opening superheat sh = 4 K

SI units R22

Valve type	Orifice no.	Cond. temp. [°C]	Evap. temp. [°C]					
			-40	-30	-20	-10	0	10
TE 5	0.5	55	4.68	5.92	7.38	9.02	10.74	12.3
	01	55	8.55	10.9	13.6	16.7	19.8	22.6
	02	55	11.9	15.3	19.2	23.4	27.8	31.4
	03	55	14.9	18.9	23.6	29.0	34.6	39.6
	04	55	19.4	25.0	31.8	40.0	47.5	54.2
TE 12	05	55	23.5	29.0	35.8	44.0	53.3	62.7
	06	55	29.1	36.5	45.9	57.4	70.7	84.2
	07	55	37.0	45.0	55.1	68.0	83.5	101
TE 20	08	55	50.5	64.3	81.1	101	123	143
	09	55	51.7	66.0	84.1	107	134	161
TE 55	10	55	52.5	71.1	94.3	123	155	187
	11	55	56.8	76.9	102	132	167	201
	12	55	59.7	81.0	108	141	179	218
	13	55	69.1	94.6	127	167	213	260

Capacity in TR. Range: -40 – 50 °F.
Opening superheat sh = 7.2 °F.

US units R22

Valve type	Orifice no.	Cond. temp. [°F]	Evap. temp. [°F]					
			-40	-20	0	20	40	50
TE 5	0.5	135	1.32	1.72	2.18	2.71	3.25	3.50
	01	135	2.42	3.15	4.03	5.01	6.00	6.44
	02	135	3.38	4.43	5.68	7.05	8.39	8.94
	03	135	4.22	5.47	6.98	8.71	10.5	11.2
	04	135	5.48	7.24	9.40	11.9	14.4	15.4
TE 12	05	135	6.61	8.32	10.5	13.1	16.1	17.6
	06	135	8.17	10.5	13.5	17.2	21.5	23.6
	07	135	10.4	12.8	16.0	20.2	25.2	27.9
TE 20	08	135	14.2	18.5	23.8	30.3	37.2	40.4
	09	135	14.5	18.9	24.6	32.0	40.7	45.0
TE 55	10	135	14.5	20.4	27.8	37.0	47.4	52.5
	11	135	15.7	22.0	30.0	39.9	50.9	56.4
	12	135	16.5	23.1	31.7	42.4	54.7	60.9
	13	135	19.0	26.9	37.2	50.2	65.1	72.6

Subcooling correction factor, f_{sub}

Subcooling [K]	2	4	10	15	20	25	30
Correction factor	0.98	1.00	1.05	1.10	1.14	1.19	1.23

Subcooling correction factor, f_{sub}

Subcooling [°F]	2	7	10	20	30	40	50
Correction factor	0.97	1.00	1.02	1.07	1.12	1.17	1.22

Distributer correction factor, f_p

SI units R22

Pressure drop [bar] Δp	Evap. temp. [°C]					
	-40	-30	-20	-10	0	10
0	1	1	1	1	1	1
1	0.96	0.95	0.95	0.94	0.93	0.91
1.5	0.93	0.93	0.92	0.91	0.90	0.86
2	0.91	0.90	0.90	0.88	0.86	0.81

Calculated at 32 °C condensing temperature.

Distributer correction factor, f_p

US units R22

Pressure drop [psi] Δp	Evap. temp. [°F]					
	-40	-20	0	20	40	50
0	1	1	1	1	1	1
15	0.95	0.95	0.95	0.94	0.92	0.91
25	0.92	0.92	0.91	0.89	0.87	0.84
30	0.91	0.90	0.89	0.87	0.84	0.80

Calculated at 90 °F condensing temperature.

Data sheet | Thermostatic expansion valves, type TE 5 – TE 55

Capacity in kW. Range: -60°C – -25°C.
Opening superheat sh = 4 K

SI units R22

Valve type	Orifice no.	Cond. temp. [°C]	Evap. temp. [°C]				
			-60	-50	-40	-30	-25
TE 5	0.5	20	2.63	3.66	4.87	6.18	6.84
	01	20	4.80	6.71	8.95	11.4	12.6
	02	20	6.68	9.38	12.6	15.9	17.6
	03	20	8.39	11.9	15.9	20.3	22.5
	04	20	11.0	15.7	21.4	27.6	30.6
TE 12	05	20	12.2	16.9	22.5	28.8	32.0
	06	20	15.9	22.1	29.9	38.7	43.3
	07	20	20.8	29.0	39.2	51.1	57.3
TE 55	9B	20	30.7	41.9	54.5	67.2	72.9
	10	20	36.3	50.4	67.5	86.3	95.7
	11	20	40.6	55.9	74.9	95.9	106
	12	20	43.3	60.4	81.4	104	117
	13	20	53.1	74.6	101	131	147

Capacity in TR. Range: -75°F – -15°F.
Opening superheat sh = 7.2 °F.

US units R22

Valve type	Orifice no.	Cond. temp. [°F]	Evap. temp. [°F]				
			-75	-60	-45	-30	-15
TE 5	0.5	65	0.76	1.00	1.27	1.57	1.88
	01	65	1.38	1.83	2.34	2.89	3.45
	02	65	1.93	2.56	3.28	4.06	4.82
	03	65	2.43	3.23	4.16	5.17	6.18
	04	65	3.19	4.29	5.58	7.00	8.41
TE 12	05	65	3.53	4.61	5.89	7.31	8.80
	06	65	4.60	6.06	7.81	9.80	11.9
	07	65	6.04	7.96	10.3	12.9	15.8
TE 55	9B	65	8.89	11.5	14.4	17.4	20.2
	10	65	10.6	13.9	17.8	22.1	26.5
	11	65	11.7	15.4	19.7	24.6	29.5
	12	65	12.6	16.7	21.4	26.8	32.3
	13	65	15.5	20.6	26.7	33.6	40.7

Capacity in kW. Range: -60°C – -25°C.
Opening superheat sh = 4 K

SI units R22

Valve type	Orifice no.	Cond. temp. [°C]	Evap. temp. [°C]				
			-60	-50	-40	-30	-25
TE 5	0.5	30	2.70	3.78	5.07	6.52	7.28
	01	30	4.90	6.90	9.30	12.0	13.4
	02	30	6.78	9.61	13.0	16.8	18.8
	03	30	8.43	12.0	16.4	21.3	23.8
	04	30	10.8	15.7	21.8	28.8	32.4
TE 12	05	30	12.1	16.9	22.8	29.7	33.4
	06	30	15.6	21.8	29.9	39.5	44.8
	07	30	19.9	28.0	38.6	51.2	58.1
TE 55	9B	30	30.0	41.3	54.6	68.7	75.5
	10	30	34.7	48.7	66.0	86.0	96.4
	11	30	38.1	53.6	72.8	95.0	107
	12	30	40.8	57.5	78.5	103	116
	13	30	49.1	69.7	95.9	127	143

Capacity in TR. Range: -75°F – -15°F.
Opening superheat sh = 7.2 °F.

US units R22

Valve type	Orifice no.	Cond. temp. [°F]	Evap. temp. [°F]				
			-75	-60	-45	-30	-15
TE 5	0.5	85	0.78	1.03	1.33	1.66	2.01
	01	85	1.42	1.89	2.44	3.05	3.71
	02	85	1.96	2.63	3.41	4.29	5.20
	03	85	2.44	3.29	4.29	5.41	6.60
	04	85	3.15	4.29	5.68	7.27	8.95
TE 12	05	85	3.51	4.63	5.98	7.53	9.23
	06	85	4.49	5.98	7.82	9.97	12.4
	07	85	5.77	7.69	10.1	12.9	16.1
TE 55	9B	85	8.69	11.4	14.4	17.7	21.0
	10	85	10.1	13.4	17.3	21.9	26.8
	11	85	11.1	14.7	19.1	24.2	29.6
	12	85	11.9	15.8	20.6	26.1	32.1
	13	85	14.3	19.2	25.1	32.1	39.8

Subcooling correction factor, f_{sub}

Subcooling [K]	2	4	10	15	20	25	30
Correction factor	0.98	1.00	1.05	1.10	1.14	1.19	1.23

Subcooling correction factor, f_{sub}

Subcooling [°F]	2	7	10	20	30	40	50
Correction factor	0.97	1.00	1.02	1.07	1.12	1.17	1.22

Distributer correction factor, f_p

SI units R22

Pressure drop [bar] Δp	Evap. temp. [°C]				
	-60	-50	-40	-30	-25
0	1	1	1	1	1
1	0.96	0.96	0.96	0.95	0.95
1.5	0.94	0.93	0.93	0.93	0.93
2	0.91	0.91	0.91	0.90	0.90

Calculated at 32 °C condensing temperature.

Distributer correction factor, f_p

US units R22

Pressure drop [psi] Δp	Evap. temp. [°F]				
	-75	-60	-45	-30	-15
0	1	1	1	1	1
15	0.96	0.96	0.95	0.95	0.95
25	0.93	0.93	0.92	0.92	0.92
30	0.91	0.91	0.91	0.90	0.90

Calculated at 90 °F condensing temperature.

Data sheet | Thermostatic expansion valves, type TE 5 – TE 55

Capacity in kW. Range: -60°C – -25°C.
Opening superheat sh = 4 K

SI units R22

Valve type	Orifice no.	Cond. temp. [°C]	Evap. temp. [°C]				
			-60	-50	-40	-30	-25
TE 5	0.5	40	2.72	3.82	5.16	6.70	7.53
	01	40	4.92	6.96	9.45	12.3	13.9
	02	40	6.76	9.66	13.2	17.3	19.5
	03	40	8.31	11.9	16.5	21.7	24.5
	04	40	10.5	15.3	21.6	29.1	33.1
TE 12	05	40	11.8	16.5	22.5	29.7	33.6
	06	40	14.8	21.0	29.1	39.1	44.6
	07	40	18.6	26.4	36.8	49.6	56.8
TE 55	9B	40	28.6	39.8	53.2	68.0	75.3
	10	40	32.3	45.8	62.7	82.7	93.5
	11	40	35.3	50.1	68.7	90.8	103
	12	40	37.5	53.3	73.4	97.5	111
	13	40	44.2	63.3	88.0	118	135

Capacity in TR. Range: -75°F – -15°F.
Opening superheat sh = 7.2 °F.

US units R22

Valve type	Orifice no.	Cond. temp. [°F]	Evap. temp. [°F]				
			-75	-60	-45	-30	-15
TE 5	0.5	105	0.79	1.05	1.35	1.70	2.09
	01	105	1.43	1.90	2.48	3.13	3.84
	02	105	1.96	2.64	3.46	4.39	5.41
	03	105	2.41	3.26	4.29	5.48	6.79
	04	105	3.03	4.17	5.60	7.29	9.16
TE 12	05	105	3.40	4.51	5.87	7.48	9.29
	06	105	4.26	5.73	7.56	9.76	12.3
	07	105	5.35	7.19	9.51	12.3	15.6
TE 55	9B	105	8.26	10.9	14.0	17.4	20.9
	10	105	9.33	12.5	16.3	20.8	25.8
	11	105	10.2	13.6	17.9	22.8	28.3
	12	105	10.8	14.5	19.0	24.4	30.5
	13	105	12.7	17.2	22.8	29.4	37.0

Capacity in kW. Range: -60°C – -25°C.
Opening superheat sh = 4 K

SI units R22

Valve type	Orifice no.	Cond. temp. [°C]	Evap. temp. [°C]				
			-60	-50	-40	-30	-25
TE 5	0.5	50	2.71	3.81	5.17	6.75	7.62
	01	50	4.87	6.91	9.44	12.4	14.0
	02	50	6.65	9.55	13.2	17.5	19.8
	03	50	8.08	11.7	16.2	21.6	24.6
	04	50	9.94	14.7	21.0	28.8	33.0
TE 12	05	50	11.2	15.8	21.7	29.0	33.0
	06	50	13.8	19.8	27.7	37.6	43.3
	07	50	17.0	24.3	34.2	46.6	53.7
TE 55	9B	50	26.9	37.6	50.6	65.4	73.0
	10	50	29.6	42.1	58.1	77.4	88.0
	11	50	32.0	45.7	63.2	84.3	95.9
	12	50	33.7	48.2	66.9	89.7	102
	13	50	38.8	56.1	78.6	107	122

Capacity in TR. Range: -75°F – -15°F.
Opening superheat sh = 7.2 °F.

US units R22

Valve type	Orifice no.	Cond. temp. [°F]	Evap. temp. [°F]				
			-75	-60	-45	-30	-15
TE 5	0.5	125	0.78	1.04	1.35	1.71	2.11
	01	125	1.41	1.89	2.46	3.13	3.88
	02	125	1.92	2.60	3.43	4.40	5.47
	03	125	2.33	3.17	4.20	5.42	6.79
	04	125	2.86	3.97	5.39	7.11	9.08
TE 12	05	125	3.21	4.29	5.62	7.22	9.05
	06	125	3.96	5.35	7.12	9.28	11.8
	07	125	4.83	6.54	8.72	11.4	14.6
TE 55	9B	125	7.68	10.2	13.2	16.5	20.1
	10	125	8.42	11.3	14.9	19.2	24.0
	11	125	9.12	12.3	16.2	20.8	26.1
	12	125	9.57	12.9	17.1	22.1	27.8
	13	125	11.0	15.0	20.0	26.0	33.1

Subcooling correction factor, f_{sub}

Subcooling [K]	2	4	10	15	20	25	30
Correction factor	0.98	1.00	1.05	1.10	1.14	1.19	1.23

Subcooling correction factor, f_{sub}

Subcooling [°F]	2	7	10	20	30	40	50
Correction factor	0.97	1.00	1.02	1.07	1.12	1.17	1.22

Distributer correction factor, f_p

SI units R22

Pressure drop [bar] Δp	Evap. temp. [°C]				
	-60	-50	-40	-30	-25
	Correction factor				
0	1	1	1	1	1
1	0.96	0.96	0.96	0.95	0.95
1.5	0.94	0.93	0.93	0.93	0.93
2	0.91	0.91	0.91	0.90	0.90

Calculated at 32 °C condensing temperature.

Distributer correction factor, f_p

US units R22

Pressure drop [psi] Δp	Evap. temp. [°F]				
	-75	-60	-45	-30	-15
	Correction factor				
0	1	1	1	1	1
15	0.96	0.96	0.95	0.95	0.95
25	0.93	0.93	0.92	0.92	0.92
30	0.91	0.91	0.91	0.90	0.90

Calculated at 90 °F condensing temperature.

Data sheet | Thermostatic expansion valves, type TE 5 – TE 55

Capacity in kW. Range: -40 – 10 °C.
Opening superheat sh = 4 K

SI units R513A

Valve type	Orifice no.	Cond. temp. [°C]	Evap. temp. [°C]					
			-40	-30	-20	-10	0	10
TE 5	0.5	25	2.12	2.79	3.56	4.37	5.02	5.10
	01	25	3.90	5.14	6.56	8.03	9.18	9.29
	02	25	5.47	7.21	9.19	11.2	12.7	12.8
	03	25	6.99	9.22	11.8	14.4	16.5	16.6
TE 12	04	25	9.39	12.5	16.0	19.7	22.5	22.5
	05	25	11.4	14.9	18.9	23.3	27.0	27.9
	06	25	14.7	19.3	24.8	30.8	36.0	37.1
TE 20	07	25	19.8	26.0	33.4	41.5	48.7	50.5
	08	25	26.8	36.0	46.7	57.8	66.4	66.1
TE 55	09	25	28.8	38.8	50.9	64.2	75.3	76.4
	10	25	32.5	44.6	59.2	75.4	89.5	93.1
	11	25	36.1	49.5	65.7	83.6	99.0	103
	12	25	39.1	53.8	71.9	92.1	110	115
	13	25	48.6	67.2	90.0	115	137	141

Capacity in TR. Range: -40 – 50 °F.
Opening superheat sh = 7.2 °F.

US units R513A

Valve type	Orifice no.	Cond. temp. [°F]	Evap. temp. [°F]					
			-40	-20	0	20	40	50
TE 5	0.5	75	0.60	0.81	1.06	1.30	1.43	1.40
	01	75	1.11	1.50	1.95	2.38	2.62	2.55
	02	75	1.55	2.10	2.73	3.32	3.62	3.50
	03	75	1.98	2.69	3.50	4.28	4.70	4.56
TE 12	04	75	2.67	3.64	4.76	5.84	6.39	6.17
	05	75	3.24	4.33	5.62	6.95	7.79	7.66
	06	75	4.19	5.65	7.39	9.21	10.4	10.2
TE 20	07	75	5.63	7.61	9.98	12.5	14.1	13.9
	08	75	7.62	10.6	13.9	17.2	18.9	18.2
TE 55	09	75	8.21	11.4	15.3	19.3	21.7	21.0
	10	75	9.29	13.1	17.8	22.8	26.0	25.6
	11	75	10.3	14.6	19.8	25.3	28.7	28.2
	12	75	11.2	15.9	21.7	27.9	32.1	31.7
	13	75	13.9	19.9	27.2	35.0	39.8	39.0

Capacity in kW. Range: -40 – 10 °C.
Opening superheat sh = 4 K

SI units R513A

Valve type	Orifice no.	Cond. temp. [°C]	Evap. temp. [°C]					
			-40	-30	-20	-10	0	10
TE 5	0.5	35	2.10	2.80	3.63	4.58	5.53	6.22
	01	35	3.86	5.15	6.68	8.42	10.1	11.4
	02	35	5.40	7.22	9.38	11.8	14.1	15.7
	03	35	6.90	9.19	11.9	15.0	18.1	20.3
TE 12	04	35	9.20	12.4	16.2	20.5	24.7	27.6
	05	35	11.2	14.7	18.8	23.7	28.9	33.2
	06	35	14.4	18.9	24.5	31.2	38.4	44.2
TE 20	07	35	19.2	25.1	32.3	41.0	50.5	58.7
	08	35	25.9	35.0	46.0	58.6	71.2	79.7
TE 55	09	35	27.4	37.0	49.0	63.4	78.9	90.5
	10	35	30.0	41.9	56.9	75.0	94.3	110
	11	35	33.1	46.2	62.8	82.7	104	120
	12	35	35.6	49.8	68.0	90.1	114	134
	13	35	43.4	61.1	83.8	111	141	164

Capacity in TR. Range: -40 – 50 °F.
Opening superheat sh = 7.2 °F.

US units R513A

Valve type	Orifice no.	Cond. temp. [°F]	Evap. temp. [°F]					
			-40	-20	0	20	40	50
TE 5	0.5	95	0.60	0.82	1.09	1.39	1.67	1.77
	01	95	1.10	1.51	2.0	2.56	3.06	3.23
	02	95	1.53	2.11	2.81	3.58	4.25	4.45
	03	95	1.96	2.69	3.58	4.57	5.48	5.76
TE 12	04	95	2.61	3.62	4.85	6.24	7.47	7.83
	05	95	3.19	4.28	5.64	7.23	8.82	9.42
	06	95	4.08	5.52	7.36	9.55	11.7	12.6
TE 20	07	95	5.45	7.33	9.70	12.5	15.5	16.7
	08	95	7.35	10.3	13.8	17.9	21.6	22.6
TE 55	09	95	7.78	10.8	14.8	19.5	24.2	25.7
	10	95	8.51	12.3	17.2	23.1	29.0	31.1
	11	95	9.39	13.6	19.0	25.5	31.9	34.1
	12	95	10.1	14.7	20.6	27.9	35.2	37.9
	13	95	12.3	18.0	25.4	34.5	43.4	46.5

Subcooling correction factor, f_{sub}

Subcooling [K]	2	4	10	15	20	25	30
Correction factor	0.98	1.00	1.07	1.13	1.18	1.24	1.31

Subcooling correction factor, f_{sub}

Subcooling [°F]	2	7	10	20	30	40	50
Correction factor	0.97	1.00	1.02	1.08	1.15	1.21	1.29

Distributer correction factor, f_p

SI units R513A

Pressure drop [bar] Δp	Evap. temp. [°C]					
	-40	-30	-20	-10	0	10
0	1	1	1	1	1	1
1	0.94	0.93	0.93	0.92	0.90	0.87
1.5	0.90	0.90	0.89	0.88	0.85	0.80
2	0.87	0.86	0.85	0.83	0.79	0.72

Calculated at 32 °C condensing temperature.

Distributer correction factor, f_p

US units R513A

Pressure drop [psi] Δp	Evap. temp. [°F]					
	-40	-20	0	20	40	50
0	1	1	1	1	1	1
15	0.93	0.93	0.92	0.91	0.89	0.87
25	0.89	0.88	0.87	0.85	0.81	0.77
30	0.86	0.85	0.84	0.82	0.76	0.71

Calculated at 90 °F condensing temperature.

Data sheet | Thermostatic expansion valves, type TE 5 – TE 55

Capacity in kW. Range: -40 – 10 °C.
Opening superheat sh = 4 K

SI units R513A

Valve type	Orifice no.	Cond. temp. [°C]	Evap. temp. [°C]					
			-40	-30	-20	-10	0	10
TE 5	0.5	45	2.03	2.72	3.57	4.56	5.66	6.69
	01	45	3.72	5.0	6.56	8.40	10.4	12.3
	02	45	5.20	7.01	9.21	11.8	14.5	17.0
	03	45	6.65	8.89	11.6	14.9	18.5	21.8
TE 12	04	45	8.78	11.9	15.7	20.2	25.2	29.7
	05	45	10.8	14.0	18.0	22.9	28.6	34.4
	06	45	13.6	17.9	23.3	30.0	37.8	45.9
TE 20	07	45	18.1	23.5	30.2	38.4	48.1	58.8
	08	45	24.5	33.0	43.5	56.1	70.3	83.7
TE 55	09	45	25.5	34.2	45.3	59.2	75.8	92.6
	10	45	26.7	37.8	52.2	70.3	91.4	113
	11	45	29.2	41.4	57.2	76.9	100	123
	12	45	31.2	44.3	61.4	83.0	109	135
	13	45	37.3	53.3	74.3	101	133	165

Capacity in TR. Range: -40 – 50 °F.
Opening superheat sh = 7.2 °F.

US units R513A

Valve type	Orifice no.	Cond. temp. [°F]	Evap. temp. [°F]					
			-40	-20	0	20	40	50
TE 5	0.5	115	0.57	0.79	1.07	1.39	1.74	1.90
	01	115	1.05	1.46	1.96	2.56	3.20	3.49
	02	115	1.47	2.04	2.76	3.60	4.47	4.84
	03	115	1.88	2.59	3.48	4.55	5.68	6.19
TE 12	04	115	2.47	3.45	4.69	6.18	7.76	8.46
	05	115	3.04	4.07	5.37	6.98	8.83	9.75
	06	115	3.83	5.19	6.94	9.15	11.7	13.0
TE 20	07	115	5.11	6.80	8.95	11.6	14.9	16.6
	08	115	6.89	9.60	13.0	17.1	21.7	23.7
TE 55	09	115	7.15	9.92	13.5	18.1	23.5	26.2
	10	115	7.45	11.0	15.7	21.7	28.5	31.9
	11	115	8.16	12.0	17.2	23.7	31.2	34.8
	12	115	8.69	12.8	18.4	25.6	34.0	38.1
	13	115	10.4	15.5	22.3	31.2	41.5	46.5

Capacity in kW. Range: -40 – 10 °C.
Opening superheat sh = 4 K

SI units R513A

Valve type	Orifice no.	Cond. temp. [°C]	Evap. temp. [°C]					
			-40	-30	-20	-10	0	10
TE 5	0.5	55	1.92	2.58	3.40	4.37	5.49	6.64
	01	55	3.51	4.73	6.24	8.05	10.1	12.2
	02	55	4.90	6.63	8.76	11.3	14.2	17.0
	03	55	6.27	8.39	11.0	14.2	17.8	21.5
TE 12	04	55	8.18	11.1	14.7	19.1	24.2	29.4
	05	55	10.1	13.1	16.8	21.3	26.7	32.7
	06	55	12.6	16.5	21.4	27.6	35.0	43.5
TE 20	07	55	16.9	21.6	27.3	34.5	43.3	53.6
	08	55	22.6	30.4	40.0	51.6	65.3	79.9
TE 55	09	55	23.2	30.9	40.7	53.0	68.2	85.7
	10	55	22.8	32.9	46.0	62.7	83.1	106
	11	55	24.9	35.8	50.0	68.2	90.3	115
	12	55	26.2	37.9	53.1	72.8	97.1	124
	13	55	30.7	44.7	63.1	87.0	117	150

Capacity in TR. Range: -40 – 50 °F.
Opening superheat sh = 7.2 °F.

US units R513A

Valve type	Orifice no.	Cond. temp. [°F]	Evap. temp. [°F]					
			-40	-20	0	20	40	50
TE 5	0.5	135	0.54	0.75	1.01	1.32	1.68	1.87
	01	135	0.98	1.37	1.85	2.44	3.10	3.43
	02	135	1.37	1.91	2.60	3.42	4.34	4.79
	03	135	1.75	2.42	3.26	4.28	5.44	6.03
TE 12	04	135	2.28	3.19	4.35	5.79	7.43	8.25
	05	135	2.82	3.75	4.92	6.38	8.14	9.09
	06	135	3.51	4.72	6.29	8.29	10.7	12.1
TE 20	07	135	4.69	6.14	7.96	10.3	13.1	14.8
	08	135	6.29	8.72	11.8	15.5	19.9	22.2
TE 55	09	135	6.43	8.82	11.9	15.9	20.9	23.7
	10	135	6.22	9.35	13.6	19.0	25.7	29.3
	11	135	6.76	10.2	14.7	20.6	27.9	31.7
	12	135	7.12	10.7	15.6	22.0	30.0	34.3
	13	135	8.30	12.6	18.5	26.3	36.1	41.3

Subcooling correction factor, f_{sub}

Subcooling [K]	2	4	10	15	20	25	30
Correction factor	0.98	1.00	1.07	1.13	1.18	1.24	1.31

Subcooling correction factor, f_{sub}

Subcooling [°F]	2	7	10	20	30	40	50
Correction factor	0.97	1.00	1.02	1.08	1.15	1.21	1.29

Distributer correction factor, f_p

SI units R513A

Pressure drop [bar] Δp	Evap. temp. [°C]					
	-40	-30	-20	-10	0	10
0	1	1	1	1	1	1
1	0.94	0.93	0.93	0.92	0.90	0.87
1.5	0.90	0.90	0.89	0.88	0.85	0.80
2	0.87	0.86	0.85	0.83	0.79	0.72

Calculated at 32 °C condensing temperature.

Distributer correction factor, f_p

US units R513A

Pressure drop [psi] Δp	Evap. temp. [°F]					
	-40	-20	0	20	40	50
0	1	1	1	1	1	1
15	0.93	0.93	0.92	0.91	0.89	0.87
25	0.89	0.88	0.87	0.85	0.81	0.77
30	0.86	0.85	0.84	0.82	0.76	0.71

Calculated at 90 °F condensing temperature.

Data sheet | Thermostatic expansion valves, type TE 5 – TE 55

Capacity in kW. Range: -40 – 10 °C.
Opening superheat sh = 4 K

SI units R134a

Valve type	Orifice no.	Cond. temp. [°C]	Evap. temp. [°C]					
			-40	-30	-20	-10	0	10
TE 5	0.5	25	2.59	3.33	4.16	5.00	5.65	5.72
	01	25	4.76	6.12	7.65	9.18	10.3	10.4
	02	25	6.69	8.60	10.7	12.8	14.4	14.4
	03	25	8.55	11.0	13.8	16.5	18.6	18.7
	04	25	11.5	14.9	18.7	22.5	25.4	25.4
TE 12	05	25	15.2	19.3	24.1	29.0	33.0	33.6
	06	25	19.7	25.2	31.6	38.4	43.9	44.8
	07	25	26.3	33.8	42.6	51.9	59.5	60.8
TE 20	08	25	30.2	39.1	49.3	59.8	67.8	68.3
	09	25	34.8	45.4	58.0	71.5	82.4	84.0
TE 55	10	25	40.0	52.7	67.7	84.0	98.1	102
	11	25	44.6	58.7	75.4	93.4	109	113
	12	25	48.5	64.0	82.6	103	121	127
	13	25	60.6	80.4	104	130	152	156

Capacity in TR. Range: -40 – 50 °F.
Opening superheat sh = 7.2 °F.

US units R134a

Valve type	Orifice no.	Cond. temp. [°F]	Evap. temp. [°F]					
			-40	-20	0	20	40	50
TE 5	0.5	75	0.73	0.96	1.22	1.47	1.61	1.57
	01	75	1.35	1.78	2.25	2.70	2.94	2.87
	02	75	1.89	2.49	3.15	3.76	4.06	3.95
	03	75	2.42	3.19	4.06	4.87	5.27	5.14
	04	75	3.27	4.33	5.53	6.64	7.18	6.97
TE 12	05	75	4.29	5.61	7.12	8.59	9.42	9.26
	06	75	5.57	7.32	9.36	11.4	12.6	12.4
	07	75	7.47	9.85	12.7	15.5	17.1	16.8
TE 20	08	75	8.57	11.4	14.6	17.7	19.3	18.8
	09	75	9.88	13.3	17.3	21.3	23.6	23.1
TE 55	10	75	11.4	15.4	20.2	25.2	28.4	28.1
	11	75	12.7	17.2	22.5	28.0	31.5	31.1
	12	75	13.8	18.8	24.7	31.0	35.2	34.9
	13	75	17.3	23.6	31.2	39.0	43.9	43.2

Capacity in kW. Range: -40 – 10 °C.
Opening superheat sh = 4 K

SI units R134a

Valve type	Orifice no.	Cond. temp. [°C]	Evap. temp. [°C]					
			-40	-30	-20	-10	0	10
TE 5	0.5	35	2.65	3.42	4.34	5.36	6.35	7.03
	01	35	4.86	6.29	7.98	9.85	11.6	12.8
	02	35	6.81	8.83	11.2	13.8	16.2	17.7
	03	35	8.70	11.3	14.3	17.6	20.8	22.9
	04	35	11.6	15.2	19.3	24.0	28.4	31.1
TE 12	05	35	15.3	19.5	24.5	30.3	36.1	40.2
	06	35	19.6	25.1	31.9	39.8	47.8	53.6
	07	35	26.1	33.3	42.1	52.5	63.2	71.1
TE 20	08	35	30.3	39.2	50.0	62.3	74.4	82.4
	09	35	34.1	44.4	57.3	72.6	88.3	99.3
TE 55	10	35	38.2	51.0	66.8	85.5	105	121
	11	35	42.3	56.4	73.9	94.4	116	133
	12	35	45.6	61.0	80.3	103	128	148
	13	35	56.0	75.3	99.4	128	159	182

Capacity in TR. Range: -40 – 50 °F.
Opening superheat sh = 7.2 °F.

US units R134a

Valve type	Orifice no.	Cond. temp. [°F]	Evap. temp. [°F]					
			-40	-20	0	20	40	50
TE 5	0.5	95	0.75	1.00	1.30	1.62	1.91	2.00
	01	95	1.38	1.84	2.38	2.97	3.49	3.65
	02	95	1.93	2.58	3.34	4.15	4.84	5.03
	03	95	2.47	3.29	4.26	5.33	6.24	6.51
	04	95	3.30	4.43	5.78	7.25	8.50	8.84
TE 12	05	95	4.35	5.67	7.31	9.17	10.9	11.4
	06	95	5.57	7.34	9.54	12.1	14.5	15.2
	07	95	7.42	9.70	12.6	15.9	19.1	20.2
TE 20	08	95	8.60	11.4	14.9	18.9	22.4	23.4
	09	95	9.69	13.0	17.2	22.1	26.8	28.2
TE 55	10	95	10.8	14.9	20.1	26.6	32.1	34.3
	11	95	12.0	16.5	22.2	28.9	35.4	37.7
	12	95	13.0	17.9	24.2	31.6	39.1	41.9
	13	95	15.9	22.1	29.9	39.3	48.5	51.7

Subcooling correction factor, f_{sub}

Subcooling [K]	2	4	10	15	20	25	30
Correction factor	0.98	1.00	1.06	1.12	1.17	1.22	1.28

Subcooling correction factor, f_{sub}

Subcooling [°F]	2	7	10	20	30	40	50
Correction factor	0.97	1.00	1.02	1.08	1.15	1.21	1.27

Distributer correction factor, f_p

SI units R134a

Pressure drop [bar] Δp	Evap. temp. [°C]					
	-40	-30	-20	-10	0	10
0	1	1	1	1	1	1
1	0.93	0.93	0.92	0.92	0.90	0.87
1.5	0.90	0.89	0.88	0.87	0.84	0.79
2	0.86	0.85	0.84	0.82	0.79	0.71

Calculated at 32 °C condensing temperature.

Distributer correction factor, f_p

US units R134a

Pressure drop [psi] Δp	Evap. temp. [°F]					
	-40	-20	0	20	40	50
0	1	1	1	1	1	1
15	0.93	0.93	0.92	0.91	0.89	0.86
25	0.88	0.87	0.86	0.84	0.80	0.76
30	0.86	0.85	0.83	0.81	0.75	0.70

Calculated at 90 °F condensing temperature.

Data sheet | Thermostatic expansion valves, type TE 5 – TE 55

Capacity in kW. Range: -40 – 10 °C.
Opening superheat sh = 4 K

SI units R134a

Valve type	Orifice no.	Cond. temp. [°C]	Evap. temp. [°C]					
			-40	-30	-20	-10	0	10
TE 5	0.5	45	2.64	3.42	4.37	5.49	6.70	7.80
	01	45	4.83	6.28	8.04	10.1	12.3	14.3
	02	45	6.75	8.80	11.3	14.1	17.2	19.8
	03	45	8.62	11.2	14.3	17.9	21.9	25.4
	04	45	11.4	14.9	19.2	24.3	29.8	34.5
TE 12	05	45	15.0	19.0	24.0	30.0	36.7	43.2
	06	45	19.0	24.3	31.0	39.1	48.5	57.5
	07	45	25.2	31.7	39.9	50.1	62.1	73.9
TE 20	08	45	29.5	38.0	48.7	61.6	76.1	89.3
	09	45	32.6	42.1	54.4	69.9	87.7	105
TE 55	10	45	35.1	47.5	63.1	82.6	105	128
	11	45	38.6	52.1	69.4	90.6	115	140
	12	45	41.4	56.0	74.7	98.1	126	153
	13	45	49.8	67.8	90.9	120	154	189

Capacity in TR. Range: -40 – 50 °F.
Opening superheat sh = 7.2 °F.

US units R134a

Valve type	Orifice no.	Cond. temp. [°F]	Evap. temp. [°F]					
			-40	-20	0	20	40	50
TE 5	0.5	115	0.75	1.00	1.31	1.67	2.06	2.23
	01	115	1.37	1.83	2.40	3.08	3.78	4.08
	02	115	1.91	2.57	3.37	4.31	5.26	5.66
	03	115	2.44	3.25	4.27	5.47	6.71	7.25
	04	115	3.23	4.34	5.75	7.42	9.14	9.87
TE 12	05	115	4.25	5.51	7.12	9.10	11.3	12.3
	06	115	5.38	7.04	9.21	11.9	15.0	16.4
	07	115	7.12	9.15	11.8	15.2	19.1	20.9
TE 20	08	115	8.34	11.1	14.5	18.8	23.4	25.4
	09	115	9.19	12.2	16.2	21.3	27.1	29.8
TE 55	10	115	9.86	13.8	18.9	25.4	32.7	36.2
	11	115	10.8	15.1	20.8	27.8	35.8	39.6
	12	115	11.6	16.2	22.3	30.1	39.1	43.5
	13	115	13.9	19.6	27.2	36.8	47.9	53.2

Capacity in kW. Range: -40 – 10 °C.
Opening superheat sh = 4 K

SI units R134a

Valve type	Orifice no.	Cond. temp. [°C]	Evap. temp. [°C]					
			-40	-30	-20	-10	0	10
TE 5	0.5	55	2.56	3.32	4.27	5.41	6.72	8.06
	01	55	4.68	6.09	7.84	9.95	12.4	14.8
	02	55	6.52	8.54	11.0	14.0	17.3	20.6
	03	55	8.34	10.8	13.8	17.5	21.8	26.1
	04	55	10.9	14.3	18.5	23.7	29.6	35.7
TE 12	05	55	14.4	18.0	22.6	28.3	35.2	42.8
	06	55	18.0	22.8	29.0	36.8	46.4	56.9
	07	55	23.8	29.4	36.6	45.8	57.3	70.4
TE 20	08	55	28.1	35.9	45.9	58.4	73.4	89.4
	09	55	30.5	38.9	49.9	64.2	82.0	102
TE 55	10	55	31.2	42.6	57.3	76.2	99.2	125
	11	55	34.0	46.5	62.6	83.1	108	136
	12	55	36.1	49.4	66.7	89.0	117	148
	13	55	42.7	58.7	79.8	107	141	179

Capacity in TR. Range: -40 – 50 °F.
Opening superheat sh = 7.2 °F.

US units R134a

Valve type	Orifice no.	Cond. temp. [°F]	Evap. temp. [°F]					
			-40	-20	0	20	40	50
TE 5	0.5	135	0.72	0.96	1.27	1.64	2.07	2.29
	01	135	1.32	1.76	2.33	3.02	3.81	4.20
	02	135	1.83	2.47	3.27	4.24	5.33	5.86
	03	135	2.34	3.11	4.09	5.31	6.71	7.40
	04	135	3.06	4.11	5.48	7.19	9.15	10.1
TE 12	05	135	4.05	5.16	6.63	8.51	10.8	12.0
	06	135	5.04	6.53	8.50	11.1	14.3	16.0
	07	135	6.67	8.37	10.6	13.7	17.5	19.6
TE 20	08	135	7.87	10.3	13.5	17.6	22.6	25.2
	09	135	8.49	11.1	14.6	19.3	25.3	28.5
TE 55	10	135	8.57	12.1	16.9	23.2	30.8	35.0
	11	135	9.34	13.2	18.4	25.2	33.5	38.0
	12	135	9.89	14.0	19.6	27.0	36.2	41.2
	13	135	11.6	16.6	23.4	32.4	43.6	49.8

Subcooling correction factor, f_{sub}

Subcooling [K]	2	4	10	15	20	25	30
Correction factor	0.98	1.00	1.06	1.12	1.17	1.22	1.28

Subcooling correction factor, f_{sub}

Subcooling [°F]	2	7	10	20	30	40	50
Correction factor	0.97	1.00	1.02	1.08	1.15	1.21	1.27

Distributer correction factor, f_p

SI units R134a

Pressure drop [bar] Δp	Evap. temp. [°C]					
	-40	-30	-20	-10	0	10
0	1	1	1	1	1	1
1	0.93	0.93	0.92	0.92	0.90	0.87
1.5	0.90	0.89	0.88	0.87	0.84	0.79
2	0.86	0.85	0.84	0.82	0.79	0.71

Calculated at 32 °C condensing temperature.

Distributer correction factor, f_p

US units R134a

Pressure drop [psi] Δp	Evap. temp. [°F]					
	-40	-20	0	20	40	50
0	1	1	1	1	1	1
15	0.93	0.93	0.92	0.91	0.89	0.86
25	0.88	0.87	0.86	0.84	0.80	0.76
30	0.86	0.85	0.83	0.81	0.75	0.70

Calculated at 90 °F condensing temperature.

Data sheet | Thermostatic expansion valves, type TE 5 – TE 55

Capacity in kW. Range: -40 – 10 °C.
Opening superheat sh = 4 K

SI units R407C

Valve type	Orifice no.	Cond. temp. [°C]	Evap. temp. [°C]					
			-40	-30	-20	-10	0	10
TE 5	0.5	25	4.62	5.82	7.18	8.56	9.66	10.0
	01	25	8.48	10.7	13.2	15.7	17.7	18.2
	02	25	11.9	15.0	18.4	21.8	24.4	24.9
	03	25	15.0	19.0	23.6	28.1	31.6	32.4
	04	25	20.1	25.6	31.9	38.2	42.9	43.7
TE 12	05	25	20.9	27.9	36.2	45.1	52.7	55.9
	06	25	26.6	35.8	46.9	59.1	69.8	74.5
	07	25	34.5	46.5	61.4	78.2	93.2	99.8
TE 20	08	25	49.3	63.2	79.4	96.4	110	114
	09	25	54.3	70.6	90.4	112	131	138
TE 55	10	25	63.6	82.2	105	130	153	166
	11	25	70.1	90.5	115	143	168	181
	12	25	75.5	97.8	125	156	186	202
	13	25	92.1	120	154	192	228	246

Capacity in TR. Range: -40 – 50 °F.
Opening superheat sh = 7.2 °F.

US units R407C

Valve type	Orifice no.	Cond. temp. [°F]	Evap. temp. [°F]					
			-40	-20	0	20	40	50
TE 5	0.5	75	1.31	1.69	2.12	2.53	2.78	2.78
	01	75	2.41	3.11	3.89	4.63	5.07	5.06
	02	75	3.38	4.36	5.44	6.42	6.96	6.91
	03	75	4.27	5.54	6.96	8.29	9.05	9.00
	04	75	5.71	7.47	9.45	11.3	12.3	12.2
TE 12	05	75	5.95	8.19	10.9	13.6	15.4	15.6
	06	75	7.58	10.5	14.1	17.9	20.5	20.8
	07	75	9.87	13.7	18.6	23.8	27.5	27.9
TE 20	08	75	14.1	18.5	23.6	28.7	31.7	31.6
	09	75	15.5	20.8	27.2	33.9	38.3	38.4
TE 55	10	75	18.2	24.1	31.3	39.1	45.2	46.3
	11	75	20.1	26.6	34.5	43.0	49.6	50.6
	12	75	21.6	28.8	37.6	47.3	55.1	56.6
	13	75	26.5	35.3	46.3	58.3	67.5	68.8

Capacity in kW. Range: -40 – 10 °C.
Opening superheat sh = 4 K

SI units R407C

Valve type	Orifice no.	Cond. temp. [°C]	Evap. temp. [°C]					
			-40	-30	-20	-10	0	10
TE 5	0.5	35	4.54	5.77	7.22	8.82	10.4	11.5
	01	35	8.34	10.6	13.3	16.2	19.0	20.9
	02	35	11.7	14.9	18.6	22.7	26.4	28.7
	03	35	14.7	18.7	23.5	28.8	33.8	37.0
	04	35	19.4	25.0	31.7	39.1	46.0	50.2
TE 12	05	35	20.2	26.7	34.7	44.2	54.0	61.6
	06	35	25.4	33.9	44.7	57.6	71.3	82.1
	07	35	32.2	42.6	56.3	73.2	91.7	107
TE 20	08	35	47.0	60.3	76.7	95.6	114	127
	09	35	50.5	65.4	84.4	108	132	151
TE 55	10	35	58.3	76.3	98.9	126	155	180
	11	35	63.9	83.5	108	138	169	196
	12	35	68.2	89.4	116	149	185	216
	13	35	81.8	108	141	181	225	262

Capacity in TR. Range: -40 – 50 °F.
Opening superheat sh = 7.2 °F.

US units R407C

Valve type	Orifice no.	Cond. temp. [°F]	Evap. temp. [°F]					
			-40	-20	0	20	40	50
TE 5	0.5	95	1.29	1.68	2.15	2.66	3.10	3.25
	01	95	2.37	3.09	3.95	4.88	5.68	5.93
	02	95	3.32	4.34	5.54	6.81	7.85	8.15
	03	95	4.16	5.45	7.00	8.67	10.1	10.5
	04	95	5.52	7.30	9.46	11.8	13.7	14.3
TE 12	05	95	5.74	7.80	10.4	13.5	16.4	17.5
	06	95	7.21	9.92	13.5	17.7	21.8	23.3
	07	95	9.15	12.5	17.0	22.5	28.2	30.3
TE 20	08	95	13.4	17.6	22.9	29.0	34.4	36.1
	09	95	14.4	19.1	25.4	32.9	40.2	42.9
TE 55	10	95	16.6	22.3	29.7	38.5	47.6	51.2
	11	95	18.1	24.4	32.4	42.1	51.8	55.7
	12	95	19.4	26.1	34.9	45.6	56.8	61.4
	13	95	23.2	31.5	42.3	55.5	69.0	74.4

Subcooling correction factor, f_{sub}

Subcooling [K]	2	4	10	15	20	25	30
Correction factor	0.98	1.00	1.07	1.12	1.18	1.23	1.28

Subcooling correction factor, f_{sub}

Subcooling [°F]	2	7	10	20	30	40	50
Correction factor	0.97	1.00	1.02	1.08	1.15	1.21	1.27

Distributer correction factor, f_p

SI units R407C

Pressure drop [bar] Δp	Evap. temp. [°C]					
	-40	-30	-20	-10	0	10
0	1	1	1	1	1	1
1	0.96	0.96	0.96	0.95	0.95	0.93
1.5	0.94	0.94	0.94	0.93	0.92	0.90
2	0.92	0.92	0.91	0.91	0.89	0.86

Calculated at 32 °C condensing temperature.

Distributer correction factor, f_p

US units R407C

Pressure drop [psi] Δp	Evap. temp. [°F]					
	-40	-20	0	20	40	50
0	1	1	1	1	1	1
15	0.96	0.96	0.96	0.95	0.94	0.93
25	0.93	0.93	0.93	0.92	0.90	0.88
30	0.92	0.92	0.91	0.90	0.88	0.86

Calculated at 90 °F condensing temperature.

Data sheet | Thermostatic expansion valves, type TE 5 – TE 55

Capacity in kW. Range: -40 – 10 °C.
Opening superheat sh = 4 K

SI units R407C

Valve type	Orifice no.	Cond. temp. [°C]	Evap. temp. [°C]					
			-40	-30	-20	-10	0	10
TE 5	0.5	45	4.34	5.52	6.96	8.65	10.4	12.0
	01	45	7.96	10.2	12.8	15.9	19.2	22.1
	02	45	11.1	14.3	18.1	22.4	26.8	30.5
	03	45	13.9	17.7	22.4	28.0	33.9	38.9
	04	45	18.2	23.6	30.2	38.0	46.3	53.1
TE 12	05	45	19.0	24.6	31.9	40.9	51.3	61.4
	06	45	23.6	31.0	40.7	53.0	67.4	81.9
	07	45	29.7	38.2	49.6	64.5	82.7	102
TE 20	08	45	43.6	55.5	70.8	89.6	111	130
	09	45	45.8	58.7	75.6	97.4	123	149
TE 55	10	45	51.5	68.0	89.2	116	147	179
	11	45	56.0	73.9	97.0	126	160	194
	12	45	59.3	78.4	103	135	172	211
	13	45	69.8	92.7	123	161	207	253

Capacity in TR. Range: -40 – 50 °F.
Opening superheat sh = 7.2 °F.

US units R407C

Valve type	Orifice no.	Cond. temp. [°F]	Evap. temp. [°F]					
			-40	-20	0	20	40	50
TE 5	0.5	115	1.22	1.60	2.07	2.61	3.17	3.42
	01	115	2.24	2.94	3.80	4.81	5.84	6.27
	02	115	3.14	4.13	5.36	6.76	8.13	8.69
	03	115	3.91	5.12	6.65	8.45	10.3	11.1
	04	115	5.13	6.82	8.97	11.5	14.1	15.1
TE 12	05	115	5.35	7.12	9.46	12.4	15.8	17.3
	06	115	6.63	8.96	12.1	16.2	20.9	23.1
	07	115	8.34	11.0	14.7	19.6	25.6	28.6
TE 20	08	115	12.2	16.0	21.0	27.2	33.9	36.8
	09	115	12.8	16.9	22.4	29.6	38.1	42.1
TE 55	10	115	14.4	19.6	26.5	35.4	45.6	50.6
	11	115	15.6	21.3	28.8	38.3	49.3	54.7
	12	115	16.5	22.6	30.6	41.0	53.3	59.4
	13	115	19.4	26.7	36.4	49.1	64.0	71.3

Capacity in kW. Range: -40 – 10 °C.
Opening superheat sh = 4 K

SI units R407C

Valve type	Orifice no.	Cond. temp. [°C]	Evap. temp. [°C]					
			-40	-30	-20	-10	0	10
TE 5	0.5	55	4.04	5.12	6.46	8.08	9.91	11.7
	01	55	7.38	9.40	11.9	15.0	18.3	21.7
	02	55	10.3	13.2	16.8	21.1	25.8	30.3
	03	55	12.8	16.3	20.6	25.9	31.9	37.9
	04	55	16.6	21.4	27.6	35.2	43.8	52.2
TE 12	05	55	17.5	22.2	28.2	36.0	45.6	56.2
	06	55	21.4	27.6	35.7	46.4	59.8	74.9
	07	55	27.1	33.7	42.6	54.5	69.9	88.1
TE 20	08	55	39.4	49.6	62.8	79.8	100	122
	09	55	40.6	51.2	65.2	83.8	109	135
TE 55	10	55	43.5	57.9	76.9	101	132	165
	11	55	47.0	62.6	82.9	109	142	178
	12	55	49.3	65.7	87.4	116	151	191
	13	55	56.8	76.3	102	136	179	227

Capacity in TR. Range: -40 – 50 °F.
Opening superheat sh = 7.2 °F.

US units R407C

Valve type	Orifice no.	Cond. temp. [°F]	Evap. temp. [°F]					
			-40	-20	0	20	40	50
TE 5	0.5	135	1.12	1.46	1.89	2.41	3.00	3.28
	01	135	2.05	2.68	3.48	4.46	5.54	6.07
	02	135	2.87	3.78	4.92	6.31	7.80	8.50
	03	135	3.55	4.63	6.01	7.72	9.65	10.59
	04	135	4.59	6.10	8.06	10.5	13.3	14.6
TE 12	05	135	4.88	6.29	8.20	10.7	13.8	15.5
	06	135	5.94	7.82	10.4	13.8	18.2	20.6
	07	135	7.54	9.53	12.3	16.1	21.1	24.0
TE 20	08	135	10.9	14.0	18.2	23.7	30.4	33.9
	09	135	11.2	14.4	18.8	24.9	32.7	37.1
TE 55	10	135	11.8	16.3	22.3	30.3	40.3	45.6
	11	135	12.7	17.5	24.0	32.6	43.2	49.0
	12	135	13.3	18.4	25.3	34.5	46.1	52.5
	13	135	15.3	21.3	29.5	40.5	54.5	62.2

Subcooling correction factor, f_{sub}

Subcooling [K]	2	4	10	15	20	25	30
Correction factor	0.98	1.00	1.07	1.12	1.18	1.23	1.28

Subcooling correction factor, f_{sub}

Subcooling [°F]	2	7	10	20	30	40	50
Correction factor	0.97	1.00	1.02	1.08	1.15	1.21	1.27

Distributer correction factor, f_p

SI units R407C

Pressure drop [bar] Δp	Evap. temp. [°C]					
	-40	-30	-20	-10	0	10
0	1	1	1	1	1	1
1	0.96	0.96	0.96	0.95	0.95	0.93
1.5	0.94	0.94	0.94	0.93	0.92	0.90
2	0.92	0.92	0.91	0.91	0.89	0.86

Calculated at 32 °C condensing temperature.

Distributer correction factor, f_p

US units R407C

Pressure drop [psi] Δp	Evap. temp. [°F]					
	-40	-20	0	20	40	50
0	1	1	1	1	1	1
15	0.96	0.96	0.96	0.95	0.94	0.93
25	0.93	0.93	0.93	0.92	0.90	0.88
30	0.92	0.92	0.91	0.90	0.88	0.86

Calculated at 90 °F condensing temperature.

Data sheet | Thermostatic expansion valves, type TE 5 – TE 55

Dimensions and weights

Element	ØD ₃ [mm]	ØD ₃ [in]
Standard	53	2.09
Range -60 – -25 °C (-75 – -15 °F)	60	2.36

Inlet side ØD ₁	L ₁ [mm]	L ₁ [in]
½ in. / 12 mm ODF	10	0.39
⅝ in. / 16 mm ODF	12	0.47
⅞ in. / 22 mm ODF	17	0.67

Outlet side ØD ₂	L ₁ [mm]	L ₁ [in]
⅝ in. / 16 mm ODF	12	0.47
⅞ in. / 22 mm ODF	17	0.67
1 ⅛ in. / 28 mm ODM	25	0.98

Valve body	L ₃ [mm]	L ₃ [in]	
Straight way	⅞ × 1 ⅛	28	1.10
	22 X 28 mm	28	1.10
	⅝ × ⅞	28	1.10
	16 X 22 mm	28	1.10
Others	25	0.98	
Angle way	⅞ × 1 ⅛	39	1.54
	22 X 28 mm	39	1.54
	Others	28	1.10

Valve body	L ₄ [mm]	L ₄ [in]	
Straight way	⅞ × 1 ⅛	97	3.82
	22 X 28 mm	97	3.82
	⅝ × ⅞	97	3.82
	16 X 22 mm	97	3.82
Others	74	2.91	
Angle way	⅞ × 1 ⅛	52	2.05
	22 X 28 mm	52	2.05
	Others	40	1.57

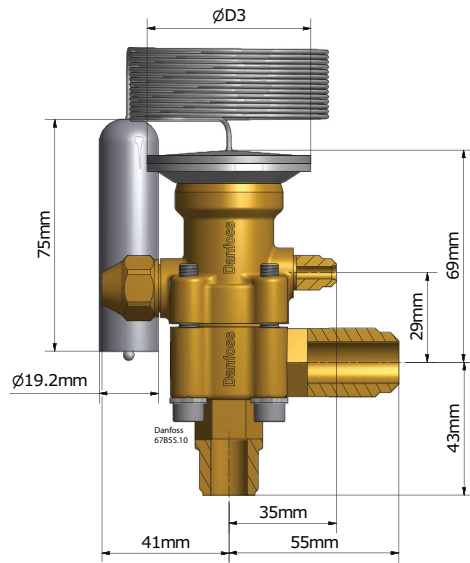

TE 5 - Flare, angleway
Weight: 1.1 kg

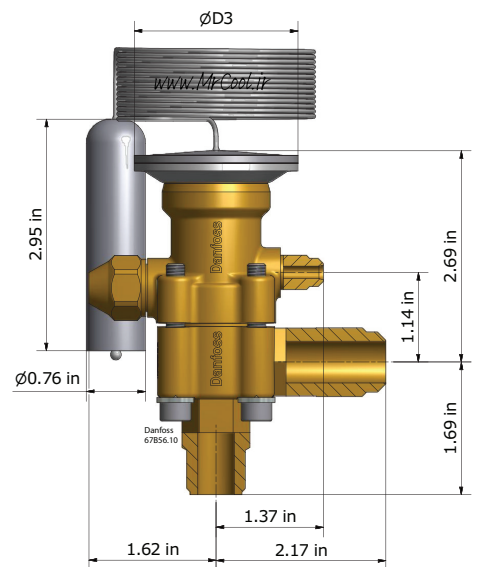

TE 5 - Flare, angleway
Weight: 2.43 lbs

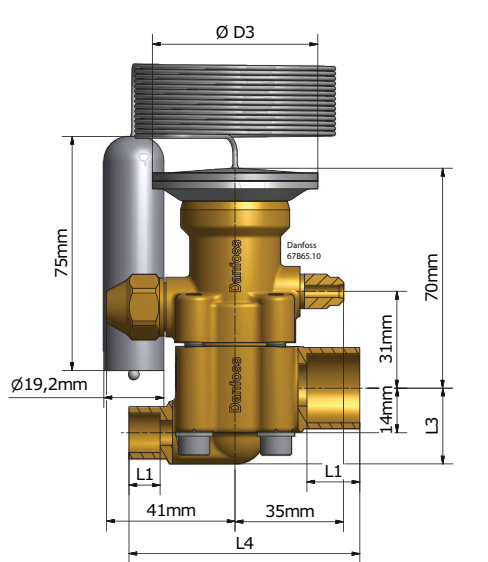

TE 5 - Solder, straightway
Weight: 1 kg

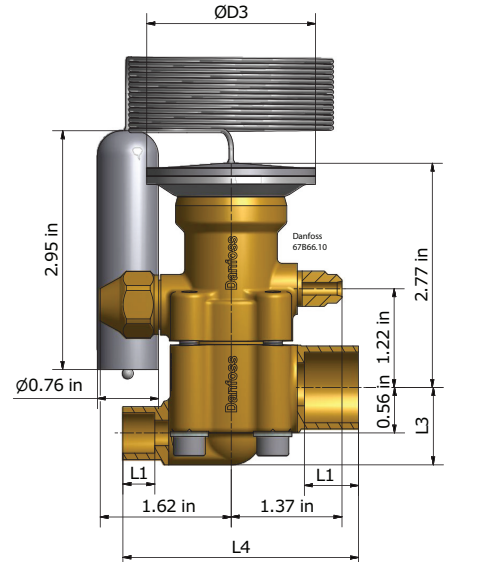

TE 5 - Solder, straightway
Weight: 2.02 lbs

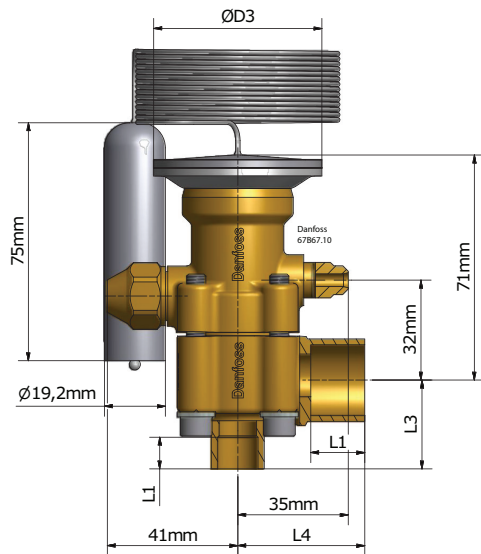

TE 5 - Solder, angleway
Weight: 1 kg

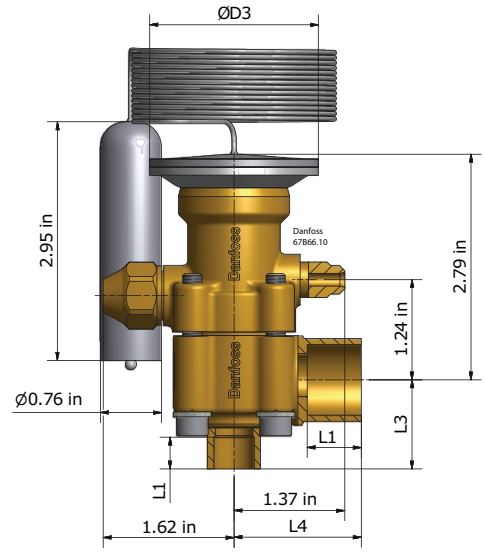

TE 5 - Solder, angleway
Weight: 2.02 lbs

Data sheet | Thermostatic expansion valves, type TE 5 – TE 55

Dimensions and weights

Element	ØD ₃ [mm]	ØD ₃ [in]
TE 12 Standard	60	2.36
TE 12 Range -60 -- -25 °C (-75 -- -15 °F)	72	2.83
TE 20	72	2.83

Bulb	L ₂ [mm]	L ₂ [in]
TE 12 Standard	75	2.95
TE 12 Range -60 -- -25 °C (-75 -- -15 °F)	120	4.72
TE 20	120	4.72

TE12 / TE20

Inlet side ØD ₁	L ₁ [mm]	L ₁ [in]
7/8 in. / 22 mm ODF	17	0.67

Outlet side ØD ₂	L ₁ [mm]	L ₁ [in]
1 1/8 in. / 28 mm ODM	25	0.98

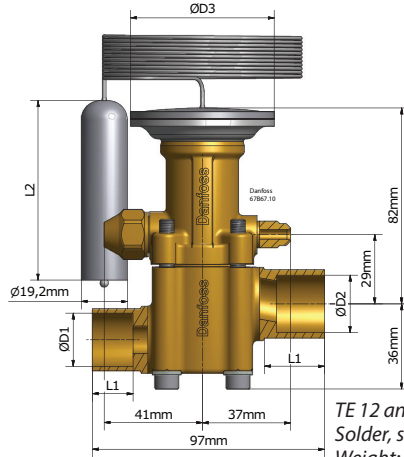

TE 12 and TE 20
Solder, straightway
Weight: TE 12: 1.5 kg
TE 20: 1.7 kg

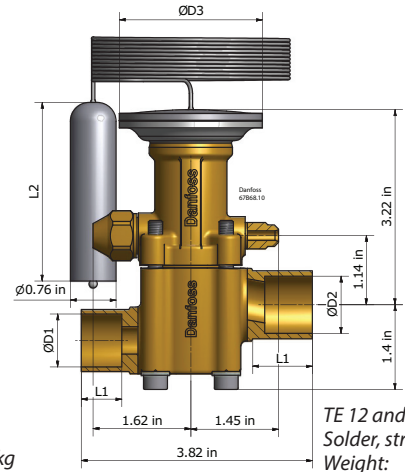

TE 12 and TE 20
Solder, straightway
Weight: TE 12: 3.31 lbs
TE 20: 3.75 lbs

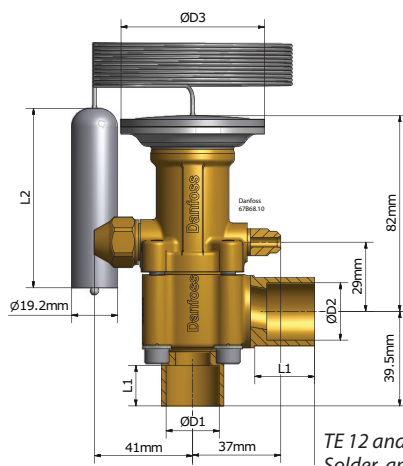

TE 12 and TE 20
Solder, angleway
Weight: TE 12: 1.5 kg
TE 20: 1.6 kg

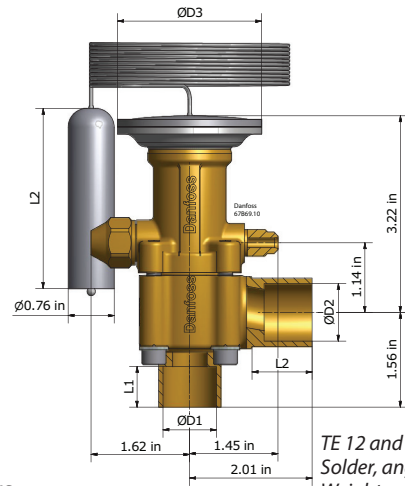

TE 12 and TE 20
Solder, angleway
Weight: TE12: 3.31 lbs
TE20: 3.53 lbs

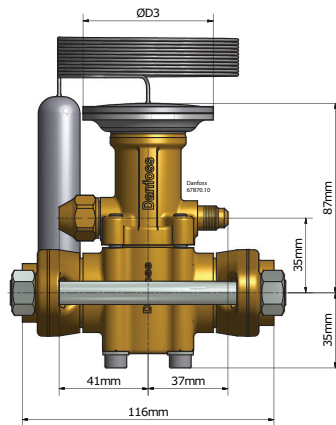

TE 12 - Solder flanges, straightway
Weight: Without filter: 2.3 kg
Weight: Without filter: 7.72 lbs

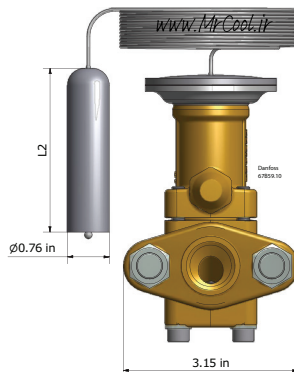
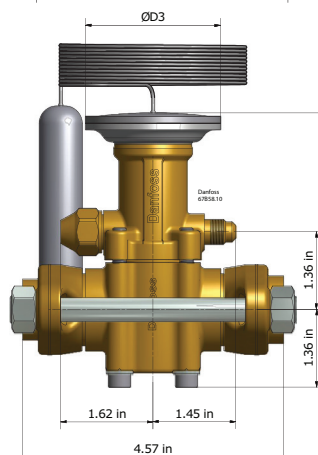
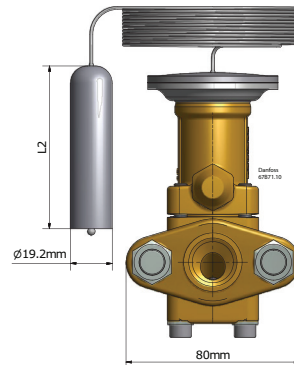

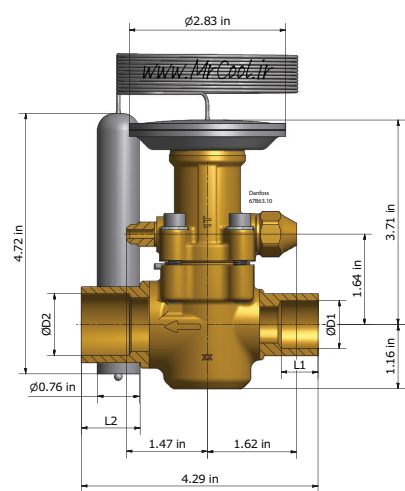
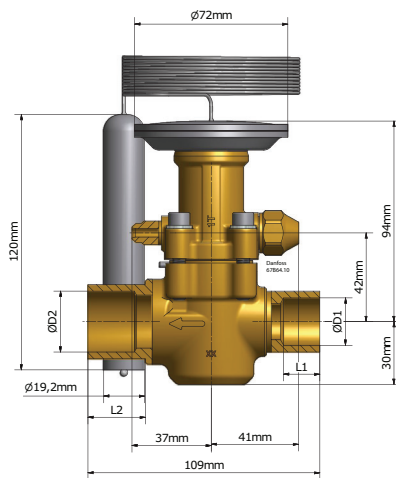

TE 55

Inlet side $\varnothing D_1$	L ₁ [mm]	L ₁ [in]
$\frac{7}{8}$ in. / 22 mm ODF	17	0.67
$1\frac{1}{8}$ in. / 28 mm ODM	25	0.98

TE 55 - Solder, straightway
Weight: 1.7 kg

TE 55 - Solder, straightway
Weight: 3.75 lbs

Outlet side $\varnothing D_2$	L ₂ [mm]	L ₂ [in]
$1\frac{1}{8}$ in. / 28 mm ODF	22	0.87
$1\frac{3}{8}$ in. / 35 mm ODM	27	1.06

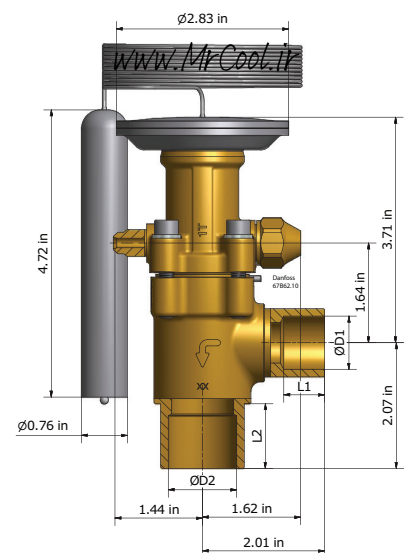
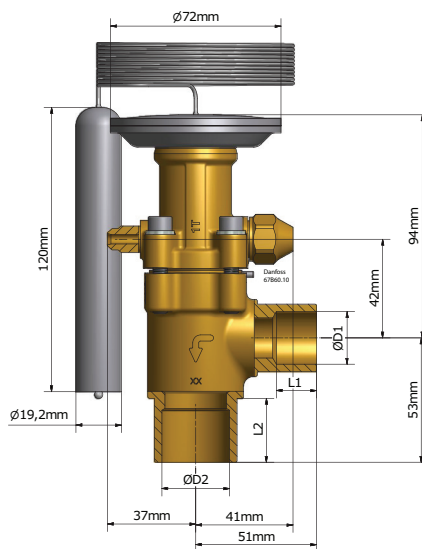

TE 55 - Solder, angleway
Weight: 1.6 kg

TE 55 - Solder, angleway
Weight: 3.53 lbs

